

# Manufacturing Sanitation Product and Latrine Construction

## Advance Short Term Training

Based on May 2023, Curriculum Version I



**Module Title: - Block Production, Lay Masonry Unit and Finishing Work**

**Module code: EIS SCW1 M05 0523**

**Nominal duration: 32 Hours**

**Prepared by: Ministry of Labor and Skill**

**May, 2023**

**Addis Ababa, Ethiopia**

## Table of Contents

Acknowledgment .....	3
Introduction to the module.....	4
Unit One: Hollow Concrete Block Production .....	5
1.1. Hollow concrete block Ingredients .....	6
1.2. Measuring and mixing ingredients.....	6
1.3. Carrying out HCB production.....	9
1.3.1. Block making Machines .....	10
1.3.1. Manual HCB making Mold.....	12
1.4. Storing and Curing of Hollow concrete block .....	15
Unit Two: Cement Stabilized Earth block production.....	19
2.1. Types of soil used for making stabilized blocks .....	20
2.2. Process of stabilized earth block production .....	20
Unit Three: Masonry Unit.....	29
3.1. Materials selection .....	30
3.2. Mortar preparation .....	30
3.3. Masonry wall construction.....	31
3.3.1. Stone.....	31
3.3.2. Hollow concrete block laying process.....	33
3.3.3. Brick .....	34
3.4. Checking quality of work.....	37
3.5. Construction of Substructure and Supper Structure.....	38
Unit Four: Finishing work .....	48
4.1. Plastering.....	49
4.2. Pointing.....	50
4.3. Rendering.....	51
4.4. Painting .....	52
4.5. Floor Finishing.....	53
Unit Five: Roof structures and sheet coverings .....	62
5.1. Setting out of roof members .....	63

5.2. Roof support installation.....	64
5.3. Roof covering installation.....	65
Bibliography .....	68
Participants of This Module (Training Material) Preparation .....	69

## Acknowledgment

The Ministry of Labor and skill would like to extend its gratitude to MoH, One WASH national Program USAID, PSI, Regional Labor, and skill/training Bureaus, TVT College Deans, Instructors, and industry experts for their financial and technical support of Manufacturing Sanitation Product and Latrine Construction training module. Finally, MOLS extends its gratitude to the following instructors and experts who contributed to the development of this TTLM until its finalization.

Mulualem Misganaw	Senior Expert /TVT Sector	MOLS
Mesfin Habtemariam (MSc)	Engineering Technical Manager	PSI/TWASH
Bacha Kitesa (Mph, MA)	WASH Capacity Development Manager	PSI/TWASH
Fisum G/Egizeebiher (BSc)	WASH Business Development Manager	PSI/TWASH
Dagim Demirew	Associate Director, WASH Business development	PSI/TWASH
Ziyad Ahmed ( Mph)	Senior Expert	MOH
Wondayehu Wube ( Mph)	Senior Expert	MOH
Andualem Abebayhu (MSC)	Instructor	Debark PTC
Mesfin Wondimu (BSc)	Instructor	Aleta Wondo PTC
Girema Moges(BSc)	Instructor	Wolayita PTC
Dagim Fekadu (MSc)	Instructor	Ambo PTC
Solomon Tadese(BSc)	Instructor	GWPTC
Esmael Mohammed (BSc)	Instructor	Kombolcha PTC
Desalegn Alemu (Bsc)	Instructor	Woliso PTC
Tesfaye Assegidew (MSc)	Instructor	Butajira PTC

## Introduction to the module

This module helps the trainees to know how hollow concrete and cement stabilized earth blocks are produced, laid, do finishing and roof cover to latrines. It helps them to meet the basic knowledge, attitudes and skills required in carrying out this short-term training operation.

### This module covers the units:

- Hollow concrete block production
- Cement stabilized earth block production
- Masonry unit
- Finishing work
- Roof Structures and Sheet Coverings

### Learning Objective of the Module

- Perform hollow concrete block production
- Perform Cement stabilized earth block production
- Lay masonry unit
- Carry out finishing work
- Construct Roof Structures and Sheet Coverings

### Module Instruction

For effective use this modules trainees are expected to follow the following module instruction:

1. Read the information written in each unit
2. Accomplish the Self-checks at the end of each unit
3. Perform Operation Sheets which were provided at the end of units
4. Do the “LAP test” giver at the end of each unit and
5. Read the identified reference book

## Unit One: Hollow Concrete Block Production

This unit is developed to provide trainees the necessary information regarding the following content coverage and topics:

- 1.1.Hollow concrete block Ingredients
- 1.2.Measuring and mixing ingredients
- 1.3.Carrying out Hollow concrete block production
- 1.4.Curing and storing of Hollow concrete block

This unit will also assist trainees to attain the learning outcomes stated below. Specifically, upon completion of this learning guide, the trainees will be able to:

- Select Hollow concrete block Ingredients
- Measure and mix ingredients
- Carry out HCB production
- Cure and storage of Hollow concrete block

## 1.1. Hollow concrete block Ingredients

### Inspecting and Selecting HCB Raw Materials

Concrete block can be produced from different construction materials with different mixing ratio as per required strength. Portland cement (OPC –ordinary Portland cement or PPC- pozzolana Portland cement), aggregates (Sand, Gravel 00, Gravel 01, Red ash or pumice), and water are common raw materials used to produce hollow concrete block.

## 1.2. Measuring and mixing ingredients

### Batching

Batching is the process of measurement of cement, coarse aggregate, fine aggregate and water for each operation of concrete making by volume using a standard measuring box of 50x40x20cm or by weight.

### Mixing

Mixing is a proportionate mixture of components such as cement, sand, aggregates, and water. The mix ratios are determined based on the type of construction and mix designs. Mixing can be performed in two ways manually by hand and mechanical mix with mixer as per given ratio.

#### a) Hand mixing

For hand mixing, a watertight platform of at least 2m by 3.5m or hard concrete surface should be provided.

### Working Procedure

Following are the steps for mixing by hand.

- a) Spread out a measured quantity of sand evenly on the mixing platform.
- b) Spread cement uniformly on the sand and mix it till the color of the mixture is uniform.
- c) Spread the above mix uniformly, then spread aggregate (others) and mix evenly.
- d) Mix the material dry until the ingredients are uniformly distributed throughout the mixture.

- e) Spread this dry mix again and make a hollow in the middle of the mixed pile and pour water slowly into it half to three quarters of the total quantity required. And then start remixing with care to avoid water escapes the mixture.
- f) Continue mixing again and again. This normally should not exceed 3 minutes.
- g) At the end of the day do not forget to wash and clean the mixing platform or surface and hand tools to make it ready for reuse.



Figure.1.1. Hand mixing

### Limitation of Hand mix

- If the situation makes with hand mix the cement content of the concrete in the mix shall be increased by 10%.
- It takes more Mixing time than machine mix
- It is difficult for mass production
- It needs additional labor cost

### b) Machine Mixing

The following are the working procedure to conduct mechanical mixing.

1. Measure the recommended water amount for the number of bags to added to the mixer and pour half of the water into the mixer (each 36.32kg bag will require about 3/4 of water). Turn the mixer on, add aggregates into the mixer and allow the mix for about a minute. Then add cement to mixer while water is added continuously as needed.
2. Mixing commonly takes about 3-5 minutes, until a uniform, workable consistency is achieved. If additional water is needed, add little by little carefully to avoid over saturation. Properly mixed concrete should look like thick oatmeal and should hold its shape when it is squeezed in a gloved hand.

**NOTE:** The more water is added to the mix, the weaker it becomes.

Page 7 of 71	Ministry of Labor and Skills	Block Production, Lay Masonry Unit and Finishing Work	Version - 1
	Author/Copyright		May.2023



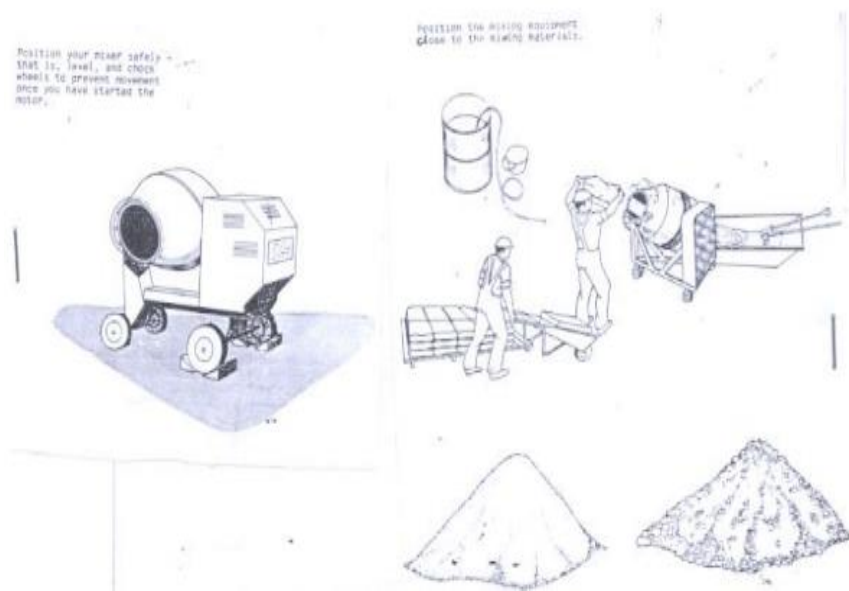

Figure:1.2 measuring and mixing

### 1.3. Carrying out HCB production

Concrete block can be hollow or solid cast with various sizes. The most common block sizes are:

- 20cm x 20cm x 40cm,
- 15cm x 20cm x 40 cm,
- 10 cm x 20 cm x 40 cm.

Blocks shall be produced under shed on a suitable smooth floor. Blocks shall remain under shed and wet cured for a minimum of 7 days after casting. The following mixing proportions for the production of hollow concrete blocks are used in accordance to ESC D3.301.

Table.1.1. Mixing proportions for HCB production

Class	Proportions by volume					Strength Block/individual N/mm <sup>2</sup>	
	Cement	Sand	Gravel 00	Gravel 01	Red ash or pumice	Average of 6 Blocks	Individual Block
A	Optional 1	2	1	1		42 kg/cm <sup>2</sup>	38 kg/cm <sup>2</sup>
	Optional 2	2	1		1		
B	Optional 1	2	1	2		35 kg/cm <sup>2</sup>	32 kg/cm <sup>2</sup>
	Optional 2	2	1		2		
C	Optional 1	3	1	2		20 kg/cm <sup>2</sup>	18 kg/cm <sup>2</sup>
	Optional 2	3	1		2		

To prepare concrete blocks on site, the following proposed proportion may use for Class C-HCB

#### Option 1

- Mix Ratio 1:2:2:2 i.e. Box Size (50x40x20) cm
- Cement (PPC).....1bag (50kg)
- Sand.....2boxes
- Pumice or Red Ash.....2boxes
- (It is possible to use both together)
- 10mm /locally called 01/ aggregate.....1box
- Very fine /locally called 00/ aggregate.....1box

**Option 2 (Minimum Requirement)**

- Mix Ratio 1:2:3:1 i.e. Box Size (50x40x20) cm
- Cement (PPC).....1bag (50kg)
- Sand.....2boxes
- Pumice or Red Ash.....3boxes
- (It is also possible to use both together)
- 10mm /locally called 01/ aggregate.....0.5box
- Very fine /locally called 00/ aggregate.....0.5box

**Option 3 (Minimum Requirement)**

- Mix Ratio 1:2.5:2.5:1 i.e. Box Size (50x40x20) cm
- Cement (PPC).....1bag (50kg)
- Sand.....2.5boxes
- Pumice or Red Ash.....2.5boxes
- (It is also possible to use both together)
- 10mm /locally called 01/ aggregate.....1box

**Output in all options**

- Expected output for 20cm thick HCB=23 Pcs
- Expected output for 15cm thick HCB=28 Pcs
- Expected output for 10cm thick HCB=33 Pcs

**1.3.1. Block making Machines**

There are several types of machines available in the market ranging from simple hand-operated to complex stationary or mobile plants. In most of the block making machines, the concrete is compacted by vibration.

**Block making procedure with Machines**

The process of manufacture of cement concrete hollow blocks involves the Following 5 stages;

**a) Proportioning:**

The determination of suitable amounts of raw materials needed to produce concrete of desired quality under given conditions of mixing, placing and curing is known as proportioning.

Page 10 of 71	Ministry of Labor and Skills Author/Copyright	Block Production, Lay Masonry Unit and Finishing Work	Version - 1 May.2023
------------------	--	--	-------------------------

**b) Mixing:**

All the raw materials including water are collected in a concrete mixer, which is rotated for about 1 ½ minutes. The prepared mix is discharged from the mixer and consumed within 30 minutes.

**c) Compacting:**

Semi-automatic vibrating table type machines are widely used for making cement concrete hollow blocks.

- Wooden pallet is kept on the vibrating platform of the machine.
- The mold box is lowered on to the pallet.
- Concrete mix is poured into the mold and evenly leveled.
- The motorized vibrating causes the concrete to settle down the mold by approximately 3.81 to 4.45cm
- More of concrete is then raked across the mold level.
- The stripper head is placed over the mold to bear on the leveled material. Vibration causes the concrete come down to its limit position.
- Then the mold box is lifted by the lever.
- The molded hollow blocks resting on the pallet is removed and a new pallet is placed and the process repeated.
- The machine can accommodate interchangeable mold for producing blocks of different sizes of hollow or solid blocks.

**d) Curing:**

Hollow blocks removed from the mold are protected until they are sufficiently Hardened to permit handling without damage. This may take about 24 hours in a shelter away from sun and winds. The hollow blocks thus hardened are cured in a curing yard to permit complete miniaturization for at least 21 days.

**e) Drying:**

Concrete shrinks slightly with loss of moisture. It is therefore essential that after curing is over, the blocks should be allowed to dry out gradually in shade so that the initial drying shrinkage of the blocks is completed before they are used in the construction work.



Figure.1.3. Block producing machine

### 1.3.1. Manual HCB making Mold.

Manual HCB making molds can be made by either timber or steel with the required dimensions.

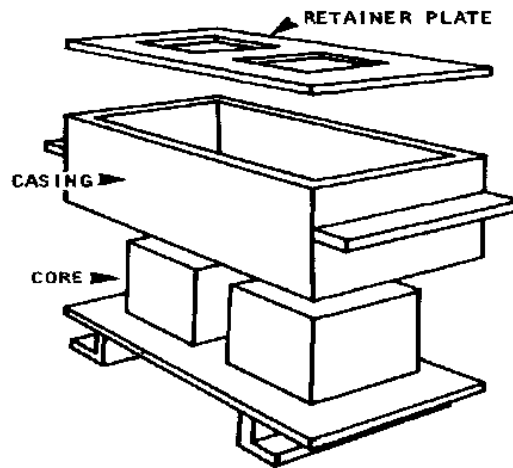

Figure-1.4. Mold made out of lumber

#### i. Casting Block with Manual Mold

Block making equipment needs to be set up and operated in line with manufacturers' instructions. The following are the steps to be followed in manual HCB production using hand and pressed compaction.

1. **Proportioning:** The determination of suitable amounts of raw materials needed to produce desired block
2. **Mixing:** The raw materials including water are collected and mix according to the given ratio.
3. **Placing:** Once the molds of the correct size have been built, shovel the wet mixture into the mold and shake them old to settle the contents. Then re-fill the mold slightly over the top and pack the mixture down with a spade or shovel. Scrape any excess off after packing thoroughly.

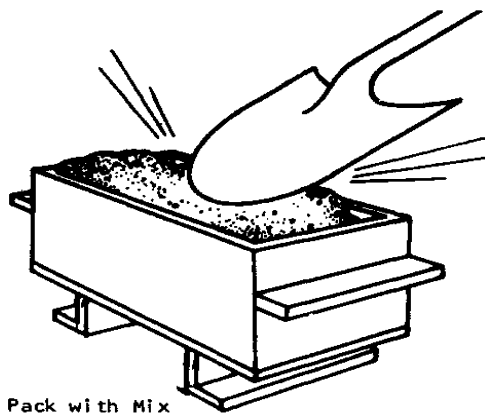

Figure.1.5. packing mold with mix

4. **Compaction:** According to Indian standard IS: manual compaction, the mixture shall be placed into the mold in layers of about 50 to 75 mm and each layer thoroughly tamped with suitable tampers until the whole mold is filled up and struck off level with a trowel.
5. **De-molding or removal of mold:** The molds should be removed carefully so that the fresh blocks are not damaged.
6. Next, carry the full mold to the curing area.

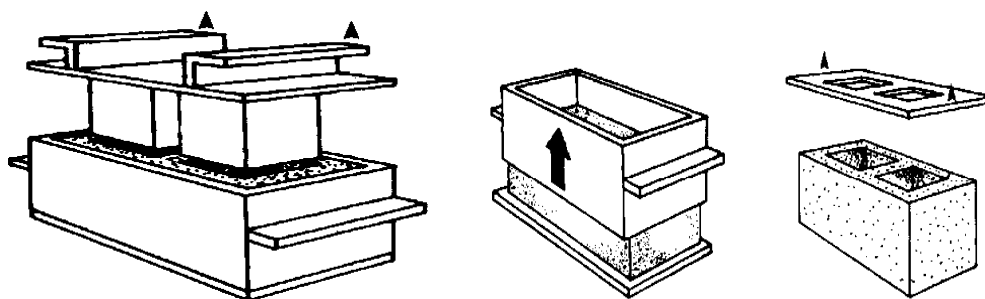

Figure-1.6. De-molding

## ii. Casting with Hand pressed

There are several types of hand press machines available for making strong concrete blocks. The following are the three basic steps in the operation of most hand pressed machine.

### 1. Loading the Mold Box

- The prepared mix is placed into the mold

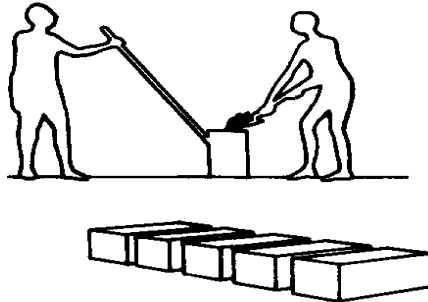

Figure-1.7. loading the mold box

### 2. Compressing the mix

- After placing the mix into mold pressure is applied with mold lever to get its shape and strength

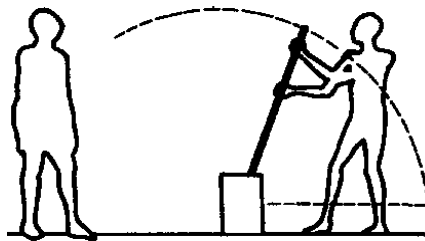

Figure.1.8. Compressing the mix

### 3. Ejecting the block

- Finally the block is ejected from the mold and stacked shaded area

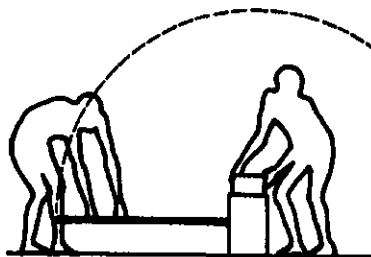

Figure-1.9 Ejecting the block

## 1.4. Storing and Curing of Hollow concrete block

### Storing

Protection of freshly cast bricks/blocks is needed to minimize damage from rain and the drying impact of sun and wind.



Figure-1.10. Shade for Freshly Cast Block Protection....

### Curing

- Curing of concrete is defined as the process of maintaining the moisture and temperature conditions of concrete for hydration reaction to normally so that concrete develops hardened properties over time.
- Concrete blocks should be sprinkled with water after they have set for about 12 hours. They should be dampened at least once a day for 7 days. They should not be laid up in a wall for at least 12 days after being produced.



Figure: 1.11. Curing of concrete block



**Self-check:1**

**Part I: Multiple choices**

**Instruction: I.** Select the correct answer for the give choice. You are provided a minute for each question and each carry 3 Points.

1. One of the follow is **not** the ingredient of HCB.

- |                     |                   |
|---------------------|-------------------|
| a) Portland cement. | c) Sand and water |
| b) Ash or pumice    | d) None           |

2. Mixing proportions for the production of hollow concrete blocks Class C is.

- |             |               |               |                    |            |
|-------------|---------------|---------------|--------------------|------------|
| a) Sand (2) | Gravel 00 (1) | Gravel 01 (1) | Red ash/pumice (0) | Cement (1) |
| b) Sand (3) | Gravel 00 (1) | Gravel 01 (2) | Red ash/pumice (0) | Cement (1) |
| c) Sand (4) | Gravel 00 (3) | Gravel 01 (2) | Red ash/pumice (1) | Cement (1) |
| d) Sand (4) | Gravel 00 (3) | Gravel 01 (3) | Red ash/pumice (2) | Cement (1) |

**Part II: Short Answer questions**

**Instruction:** write short answer for the given question. You are provided 3 minute for each question and each has 5 Points.

1. For how many days should be a new HCB needs to be cured?
2. What are the different methods of mixing hollow concrete block ingredients?

**Note: Satisfactory rating – 75% and above points**

**Unsatisfactory - below 75% points**

You can ask you teacher for the copy of the correct answers.

Name: \_\_\_\_\_

Date: \_\_\_\_\_

### Operation sheet: 1 – Mixing Concrete Block Making Ingredients

**PURPOSE:** -To make the concrete block mass homogeneous and uniform in color while maintaining the required consistency

**Conditions or Situations for The Operations:-**

- ✓ Ensure the work shop hazard free
- ✓ Ensure Availability of appropriate clothes
  - Safety shoe
  - A dust mask
  - Gloves
  - Safety glasses

**EQUIPMENT AND TOOLS**

- ✓ Builders shovel
- ✓ Measuring box
- ✓ Wheelbarrow or buckets

**MATERIALS: -**

- ✓ Cement
- ✓ Sand
- ✓ Aggregate
- ✓ Red-ash/ or pumice
- ✓ Water

**PROCEDURE,**

- ✓ Identify job specifications
- ✓ Clear the working area
- ✓ Measure out the materials.
- ✓ Place the aggregate and sand on working area
- ✓ Place the cement on top of sand and aggregate.
- ✓ The mix should be turned over many times with a spade or other suitable tool until you get uniform in color.
- ✓ Make a deep crater in the mix and add water.
- ✓ Fold the mix in from the sides.
- ✓ Mixing is continue until a homogeneous mix is obtained

**PRECAUTIONS:-**

- ✓ Wear working cloths which properly fit with your body
- ✓ Wear Mask
- ✓ Make working area hazard free.
- ✓ The water used for mixing should be free from all harmful organic substances
- ✓ Mixed materials must be laid at the required site within 20 minutes after adding water to the cement.

**QUALITY CRITERIA:**

- ✓ The concrete should be mixed thoroughly to form a homogeneous mix.
- ✓ The water cement ratio should be appropriate, considering the strength and workability criteria.
- ✓ The concrete mix should be designed properly and should have all the ingredients in right proportions.

<b>LAP Test -1</b>	<b>Practical Demonstration</b>
--------------------	--------------------------------

Name: \_\_\_\_\_

Date: \_\_\_\_\_

Time started: \_\_\_\_\_

Time finished: \_\_\_\_\_

**Instructions:** Given necessary templates, tools and materials you are required to perform the following tasks within **20** minutes

**Task-1:** Mix Block Making Ingredients

## Unit Two: Cement Stabilized Earth block production

This unit to provide trainees the necessary information regarding the following content coverage and topics:

- 2.1. Types of soil used for making stabilized blocks
- 2.2. Process of stabilized earth block production

This guide will also assist trainees to attain the learning outcomes stated below. Specifically, upon completion of this learning guide, the trainees will be able to:

- Identify Types of soil used for making stabilized blocks
- List Process of stabilized earth block production`

## 2.1.Types of soil used for making stabilized blocks

Soil types are generally classified as principal soil fractions: gravel, sand, silt and clay. The basic material required to manufacture stabilized earth blocks are a soil containing a minimum quantity of silt and clay.

Figure 2.1 - Soil classification according to particle size

Name of fraction	Diameter size ranges of particles (mm)
Gravel	2 - 60.000
Sand	0.06 – 2
Silt	0.002 - 0.06
Clay	less than 0.002

## 2.2.Process of stabilized earth block production

Modifying soil properties by adding another material to improve its durability is called soil stabilization. When a soil is successfully stabilized one or more of the following effects will be evident.

- Strength and cohesion of the soil will increase,
- Permeability of the soil will be reduced
- The soil will be made water repellent
- The durability of the soil will increase
- The soil will shrink and expand less in dry and wet conditions.

The most commonly used stabilizers are Portland cement, lime, bitumen, and others locally available materials like animal dung, straw etc. The use and adoption of the right stabilization method can improve the compressive strength of a soil by as much as 400 to 500% and increase its resistance to erosion and mechanical damage.

## **Soil Stabilization Techniques**

There are several widely used methods and techniques of soil stabilization. Some of the major techniques are described below.

### **Mechanical stabilization**

This involves tamping or compact the soil by using a heavy weight to bring about a reduction in the air void volume, thus leading to an increase in the density of the soil.

### **Cement stabilization**

The basic function of cementation is to make the soil water-resistant by reducing swelling and increasing its compressive strength. Cement can be used with any soil type, but with clays it is uneconomical because more cement is required. The range of cement content needed for good stabilization is between 3% and 18% by weight according to soil type.

### **Lime stabilization**

Lime is a suitable stabilizer for clay soils as they are more widely available and cheaper than cement. Different studies recommend that when lime is used as a stabilizer instead of cement, the quantity needs to be doubled but this may not be necessary if a sufficiently high compacting effort is applied on a high clay content soil.

### **Gypsum stabilization**

Gypsum is a good stabilizer for sandy soils.

### **Other locally available stabilizers**



Traditionally, many stabilizers such as straw, animal dung, Termite hill materials, bird droppings, plant extracts and animal blood, have been used for the manufacture of compressed stabilized earth blocks.

Page 21 of 71	Ministry of Labor and Skills Author/Copyright	Block Production, Lay Masonry Unit and Finishing Work	Version - 1 May.2023
------------------	--	--	-------------------------

## Soil-Cement stabilized Blocks Production Process

The following table shows the steps to follow to produce cement stabilized blocks.

Table: 2.2. Soil-Cement Blocks Production Process with Mold

<p><b>Step 1: Analysis of the soil</b></p> <p>Soil contains mainly gravel, sand, silt and clay size fractions. The strength and durability characteristics of soil-cement blocks mainly depends upon soil composition, block density and cement content. Soils containing predominantly non expansive clay minerals with 60 -70% sand, and &lt;15% clay size fractions are ideally suited for soil-cement block production.</p>	
<p><b>Step 2: Sieving of soil</b></p> <p>Soil should be dried and sieved (to remove large lumps, stones, leaves, and other impurities) before it can be used properly mixed with cement and compressed into blocks. Metallic 5mm sieve can be used for sieving of soil.</p> <p>The soil has the proper moisture content for sifting when (1) a handful can be squeezed without water appearing on its surface, and (2) the ball of soil disintegrates without lumps as it is released</p>	
<p><b>Step 3: Preparation of the mix</b></p> <p>Once soil has been dried and sieved, we can begin to prepare the mix from which blocks will be pressed. The amount of Portland cement to be used will depend on the composition of the soil. Sandy soils require 5 to 9% cement by volume. Silty soils need 8 to 12%, and clayey soils require 12 to 15% cement as stabilizer. More than 15% by volume is not recommended.</p> <p>Mix thoroughly all the ingredients: cement (1 bag=50kg), soil (7 parts), and sand (2 parts). After drying mixing of all the ingredients, water is added a little at a time until the damp soil-cement reaches the right consistency. We can use a garden hose with the nozzle adjusted to produce a fine spray. A concrete mixer machine is suitable for preparing the mix.</p>	 

Do the simple test to know the right consistency of the mix. Take a small amount of mix and form it into a ball in your hand, the resulting clod should both hold its shape and not stain your palm. Soil preparation has to be carried out in batches such that the wetted soil-cement mixture should be converted into blocks within 40 minutes. This is mainly to avoid setting of the cement before pressing into a block. Generally, soil sufficient for 25 blocks is processed in each batch. 1 part = box size (50cm\*40cm\*20cm)



#### Step 4: Compaction of the blocks

The processed soil is compacted into a block using a machine. This operation consists of the following activities: (a) Feeding the processed soil into the mold, (b) block compaction and (c) block ejection.

The prepared mix is placed into the mold of the machine and pressure is applied and after compaction, the block formed is ejected from the mold and stacked. Delicate touch is needed for removing the fresh blocks from the mold and stacking, as blocks are plastic and fragile when newly formed.



#### Step 5: Curing of the blocks

- Place the blocks as soon as possible on a flat, non-absorbent surface in a shady environment to cure.
- Set each block on edges and space the blocks far enough apart so that they do not touch each other.
- After 24 hours of molding blocks must be thoroughly sprinkled three times a day with the fine water spray.
- The slower the block dry, the stronger they will be. So, during the first four days of curing, blocks be covered with plastic.





- Blocks may be stacked after four days, but the sprinkling should be continued for another eight days. The blocks can be stacked one above the other up to 6 layers.

Finally, three weeks after leaving the mold, the blocks can be used in construction.



### Mud block for toilet construction

- Mud block made of clay soil mixed with straw were produced and used for construction of toilet wall. 30x25x15cm mold made of wood is prepared and used for casting. After casting blocks are left to dry for 3-5days and used for construction.
- Clay is used for binding material while laying blocks. Both Internal and external parts need to be leveled and smoothed with a mix of clay and sand. Wait till wall are dried before next step. Roughcast the external wall with a mix of clay and sand (1:3) sprayed using manual machine. After waiting at least one day, oil is applied to avoid washing by rain or water. The toilet floor is made like above.
- This option is to replace wood and mad structure which is common method in rural areas. 240 blocks are needed to construct 1.4 x 1.4 x 2.2m latrine.



Figure: 2.1. Mud block production



Figure: 2.2. Toilet wall construction with mud block



Figure: 2.3. Plastering of toilet mud wall with cement mortar

**Self-check:2**

**Part I: Multiple choices**

**Instruction:** Select the correct answer for the give choice. You are provided one minute for each question and each question carries 3 Points

1. One of the follow is included under the classification of soil?
  - a) Gravel
  - b) Silt and Clay
  - c) Sand
  - d) All of the above
  
2. One of the following operation processes is used in Cement stabilized earth block making activities
  - a) Feeding the processed soil into the mold
  - b) Compaction of mix
  - c) Block ejection
  - d) All of the above
  
3. When a soil is successfully stabilized one or more of the following effects will be evident.
  - a) Strength and cohesion of the soil will increase,
  - b) Permeability of the soil will be reduced
  - c) The soil will shrink and expand less in dry and wet conditions
  - d) All of the above

**Part II: Short Answer questions**

**Instruction:** write short answer for the given question. You are provided three minute for each question and each point has 5Points.

1. What is the main objective of soil stabilization?
2. What are the steps in soil-cement stabilized blocks production process?

**Note: Satisfactory rating – 75% and above points**

**Unsatisfactory - below 75% points**

You can ask you teacher for the copy of the correct answers.

Name: \_\_\_\_\_

Date: \_\_\_\_\_

<b>Operation Sheet 2: Producing Soil-Cement Blocks</b>	
<b>PURPOSE:</b> -To produce soil cement block as per the required quality and strength.	
<b>Conditions or Situations for The Operations:-</b> <ul style="list-style-type: none"> <li>✓ Ensure the working area hazard free</li> <li>✓ Ensure Availability of appropriate clothes               <ul style="list-style-type: none"> <li>• Safety shoe</li> <li>• A dust mask</li> <li>• Gloves</li> <li>• Safety glasses</li> </ul> </li> </ul>	<b>EQUIPMENT AND TOOLS</b> <ul style="list-style-type: none"> <li>✓ Builders shovel</li> <li>✓ Measuring box</li> <li>✓ Metallic 5mm sieve</li> <li>✓ Wheelbarrow or buckets</li> <li>✓ Trowel</li> <li>✓ Block Making Mold</li> </ul>
<b>Materials: -</b> <ul style="list-style-type: none"> <li>✓ Cement</li> <li>✓ Sandy soils</li> <li>✓ Silt soils</li> <li>✓ Clayey soils</li> <li>✓ Water</li> </ul>	<b>Procedures</b> <ul style="list-style-type: none"> <li>✓ Identify job specifications</li> <li>✓ Prepared working area</li> <li>✓ Analysis of the soil</li> <li>✓ Preparation of the mix</li> <li>✓ Compaction and Curing of blocks.</li> </ul>
<b>Precautions:-</b> <ul style="list-style-type: none"> <li>✓ Wear working cloths which properly fit with your body</li> <li>✓ Wear Mask</li> <li>✓ Make working area hazard free.</li> <li>✓ The water used for mixing should be free from all harmful organic substances</li> <li>✓ Producing block must be laid at the required site within 30 minutes after adding water to the cement.</li> </ul>	
<b>Quality criteria:</b> <ul style="list-style-type: none"> <li>✓ The raw materials should be mixed thoroughly to form a homogeneous mix.</li> <li>✓ The water cement ratio should be appropriate, considering the strength and workability criteria.</li> <li>✓ The materials mix should be designed properly and should have all the ingredients in right proportions.</li> </ul>	

<b>LAP Test -2</b>	<b>Practical Demonstration</b>
--------------------	--------------------------------

Name: \_\_\_\_\_

Date: \_\_\_\_\_

Time started: \_\_\_\_\_

Time finished: \_\_\_\_\_

**Instructions:** Given necessary templates, tools and materials you are required to perform the following tasks within **60** minutes

**Task-2:** Produce Soil-Cement Blocks

## Unit Three: Masonry Unit

This unit to provide trainees the necessary information regarding the following content coverage and topics:

- 3.1. Materials selection
- 3.2. Mortar preparation
- 3.3. Masonry wall construction
- 3.4. Checking quality of work
- 3.5. Construction of Substructure and Supper Structure

This guide will also assist trainees to attain the learning outcomes stated below. Specifically, upon completion of this learning guide, the trainees will be able to:

- Apply Materials selection
- Carry out Mortar preparation
- Carry out Masonry wall construction
- Check quality of work
- Apply Construction of Substructure and Supper Structure

### 3.1. Materials selection

#### Selecting appropriate Material

Commonly, we use concrete & stabilized soil blocks, stone and brick for construction of wall and pit lining works. The material will be selected as per site specific need, availability, cost and others.

### 3.2. Mortar preparation

Mortar is a material composed of fine aggregate and cement which forms a hardened mass after mixing with water. It is used in the beds and site joints of masonry work in order to bind the stones, bricks or blocks together and thereby distribute the pressure throughout the block work.



Figure 3.1. Ingredients of cement

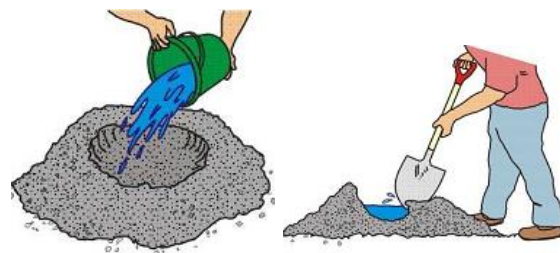

Figure. 3.2. Mixing of ingredients

#### Work method:

1. Place and spread sand on a clean platform or hard surface.
2. Add cement on top of the sand.
3. Thoroughly mix the sand and cement until a uniform grey mixture is achieved.

The general rule is that: sand and cement is mixed dry together at least three times before adding water. It is important to achieve a consistently uniform mix.

4. Rake the mix together and dig a well in the center of the heap and carefully add water. Add the water in portions to avoid ending up with a too wet mix.
5. Carefully shovel the dry mix into the water in the middle of the heap and continue mixing until the mortar has a uniform mass with the preferred consistency.

### 3.3. Masonry wall construction

#### 3.3.1. Stone

##### Laying stone

Horizontal and vertical alignments in the laying stones are carried out in the same procedure i.e. leveling with spirit level, straight edge, string; plumbing using plumb bob, etc. Place stones bond at frequent intervals thereby increasing the cohesive strength of the wall.

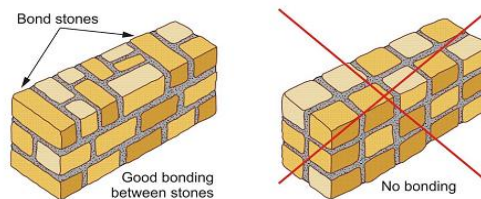

Figure.3.3. Vertical Alignments of Bonding between stones

#### Steps in Stone masonry Construction using cement mortar

##### 1. Preparation

- Set out exactly the proposed structure by marking the sides of the walls on the foundation or the trench bed.
- Clean the foundation with a steel brush, wet it properly and if necessary rough it by chiseling.
- Two masons commonly work at the same time inside and outside of the wall.
- Use crack-free stone.
- A stiff mortar should be used. Never fill the inside of the wall with slurry mortar because this will reduce the strength.

##### 2. Construction

- Use largest and straightest stones on the ground and as corner stones.
- Use two-faced shaped and squared stone for corners as well as for the top of the wall.
- The stones are laid on a mortar bed and then tapped gently into the mortar with a hammer.
- Build the corner stone's inside and outside, then stretches a string on each side and build in between these lines.



- Leftover mortar from each course should be cleaned from the stones as well as from the ground and can be used in the next course.
- The overlap of the stones in consecutive courses should be minimum 10cm.

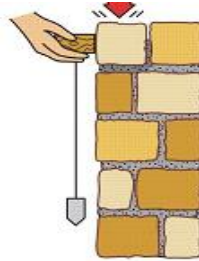

Figure.3.4 Checking Vertical Alignment of Wall

- The face and the inner part of the wall should be built at the same time.
- The joints should not be thicker than 2.0-2.5 cm but never less than 1.0 cm, depending on the size of the stone.
- Small pieces of stone are used for better seating of the shaped stone but they should not be visible at the outside of the wall. These stone chips need to be well embedded in mortar.

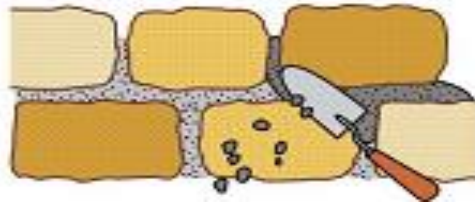
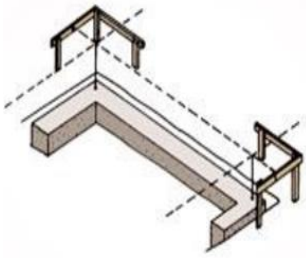
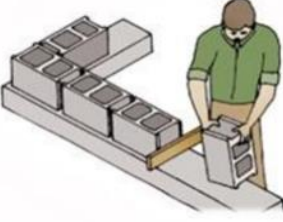
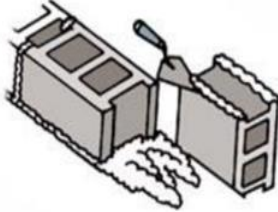
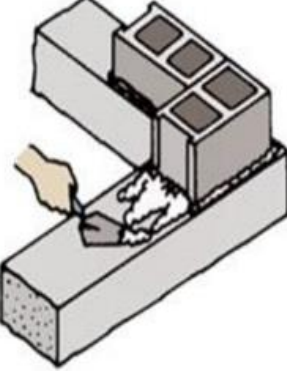
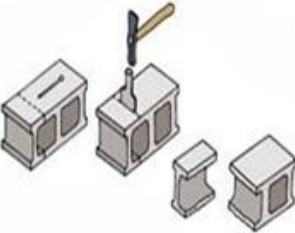

Figure.3.5 Removing of any excess mortar



Figure.3.6 Sample of masonry work

### 3.3.2. Hollow concrete block laying process

<ul style="list-style-type: none"> <li>• Before starting to lay the blocks, drive stakes into the ground and build a form at each corner.</li> <li>• Locate the exact corner by stretching lines from one corner form to the other as illustrated.</li> <li>• The exact corner will be the point at which the two lines cross.</li> </ul>	
<p>a) Drop a plumb bobs down from each line, both at the corner point where the lines cross and at positions about 5.1cm out in each direction.</p>	
<p>b) Be sure to use the corner blocks where needed, and cut blocks as required.</p> <p>c) Use scrap pieces of 1cm plywood to fill in the mortar joint between each block. This is the thickness of the mortar when applied.</p>	
<ul style="list-style-type: none"> <li>• After this test run, remove the blocks and prepare for the actual laying of the first course.</li> <li>• Drop plumb bobs down from the corner string and at positions about 3' out from the corner. Mark the location of the corner block on the footing base as shown.</li> <li>• Spread the mortar out about 2.5cm deep and 20.3cm wide in the marked area. Extend this mortar out for a distance of about three or four blocks in one direction.</li> </ul>	
<ul style="list-style-type: none"> <li>• Put a furrow in the center of the mortar with a trowel. Furrow will force the mortar to the edge of the block when it is laid.</li> <li>• Set the corner block first/finished end.</li> <li>• Check the starting corner block, both horizontally and vertically, and take time to get it positioned correctly. All other blocks will align with this starter block, so it's very important to set it exactly.</li> </ul>	

**Note:**

- Follow this same procedure as you reach the other corners, laying the first course out about two or three blocks in each direction.
- Tie a line between two bricks and stretch it between the two corner blocks on the first course.

**3.3.3. Brick**

**Types of Bricks**

- There are different types of bricks available on the market used for various purposes.
- Bricks can broadly be categorized into two types as follows on the basis of how its manufactured:
  - Un burnt or sun-dried brick
  - Burnt bricks
- According to Ethiopian standard, brick size is 25cm×12cm×6cm.

**Brick Bonds**

- The term bonding means the arrangements of bricks in which no vertical joint of one course is exactly over the one below. That means the brick is laid in such a way that it overlaps and breaks the joint below.
- The amount of lap is generally half of the length of a brick.
- Common types of Bond used in laying bricks are:
  - Stretcher Bond
  - Header Bond
  - English Bond
  - Flemish Bond
- The simple common brick bonds are Stretcher and header. They are explained as below.

**Stretcher Bond**

- Bricks are laid horizontally and flat with a long side called a stretcher and in this bond, all brick is laid as stretchers, which is lengthwise shown in figure below.
- Sometimes stretcher bond is also known as a running bond.

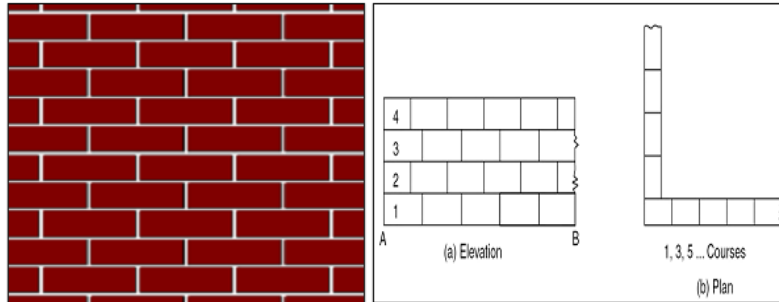

Figure-3.12. Stretcher Bond

### Header Bond

Header is the shorter square face of the brick which measures 6cm x 12cm. It is composed of header bricks, set in rows that are offset  $\frac{3}{4}$  of a brick as a quoin brick in alternating courses, which produces a solid easy to lay bond.

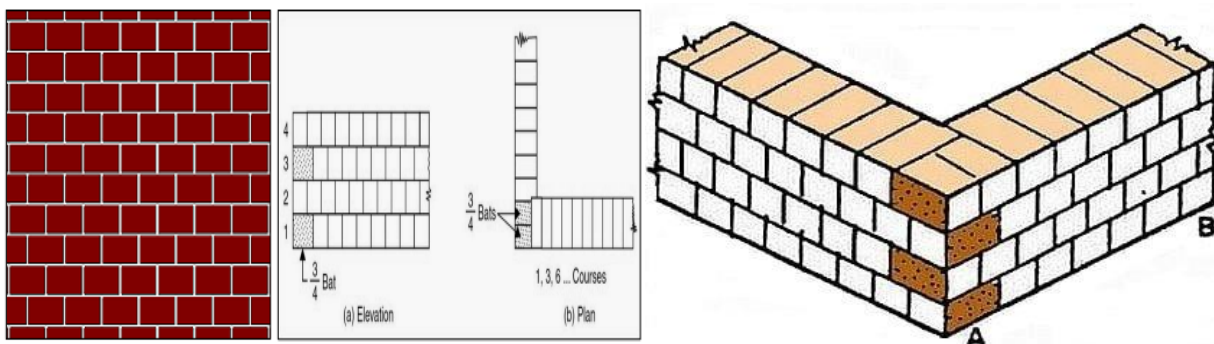

Figure-3.13. Header Bond

In order to obtain a good bond it is necessary to insert “bats” (parts of bricks). Some of the commonly used brick terms are:

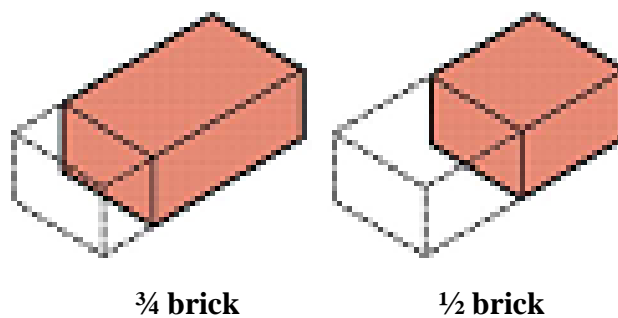

Figure-3.14. Brick bats

## Laying Brick

- Bricks are small rectangular blocks that can be used to build parts of buildings.
- Bricks are made from clay.
- The building procedure for bricks or blocks is the same.
- Bricks and blocks must be bonded to give maximum strength and adequate distribution of loads over the wall.

## Steps in brick work construction

The rules required for construction in brick work are:

- Lay out exactly the proposed structure by marking the external side of the walls on the foundation
- Clean the foundation with a steel brush, wet it properly, if necessary rough it by chiseling.
- Lay the first two courses without mortar to check that the correct bond is achieved.
- Cement bricks are cleaned and sprinkled with water; burned bricks are soaked in water for one minute before using them. This is important so that the water of the mortar is not soaked away by the bricks or blocks, which would reduce quality and strength. If the brick is not clean, it will reduce the strength of binding with the mortar, as well as producing cracks caused by swelling and shrinking.
- Check every brick for its brittleness (sound test by kicking with hammer) before using it for construction.
- Lay the corners exactly with mortar and stretch a line from one corner to the other. There after build the first course in between these marked lines.
- In order that all courses have the same height, use a baton (straight edge) marking all courses on it.
- Build the corners 4 to 5 courses high, and then work along the line.
- Make sure each course is exactly horizontal by using a spirit level.
- Build the walls exactly vertical by using a spirit level or a plumb bob line.
- Use the same bond throughout the job.

### 3.4. Checking quality of work

#### Quality checkpoints:

- Check that all corners remain vertical at all times.
- Check that the level of each course is correct (height of courses = one brick/block plus one joint)
- Ensure the mason's line is tightly pulled to avoid any sagging.
- Make sure that the joints are not less than 10mm and not more than 15mm.
- All joints should be fully filled with mortar.
- Use a plumb bob to check that every wall is vertical.
- Immediately remove excess mortar protruding from the joints.
- In hot weather, cover the completed wall with wet gunny bags at the end of the day.

A plumb bob is a pointed weight attached to the end of the string and is used to find a vertical reference line called plumb. The string is fixed at the point to be plumbed. The weight, or bob, is then allowed to swing freely; when it stops, the point of the bob is precisely below the point at which the string is fixed above.

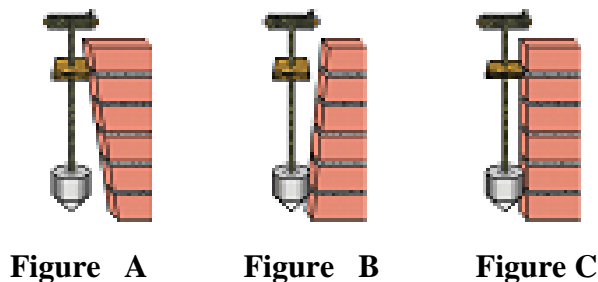

Figure.3.15 checking vertical alignment with plumb bob

#### Notice:

- From the figure shown above, figure A & B vertical alignments are incorrect whereas figure C has correct alignment.
- For checking horizontal levels while carrying out masonry works, spirit level is used in combination with a straight edge for checking longer objects.



Figure-3.16: checing horizontal alignment with sprit level

### 3.5. Construction of Substructure and Supper Structure

#### Substructure wall construction

- Substructure: part of the building, which is located below the grade beam or the ground floor level.
- In toilet construction, pit lining is mandatory in unstable soils and areas where the water table is higher.
- Construction starts from the bottom part of the excavated hole.

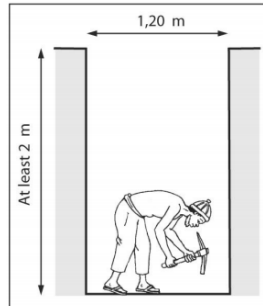

Figure.3.17 shape of Excavation

- The whole pit will be lined with concrete block/brick masonry

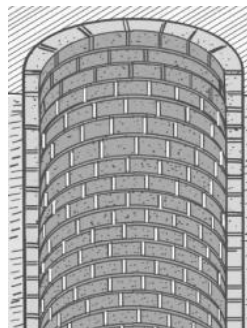

Figure.3.18 Erecting circular wall



Figure.3.19. Erecting rectangular wall

### Costruction pit in stable soils

- The depth of the pit will be vary as per the owner need

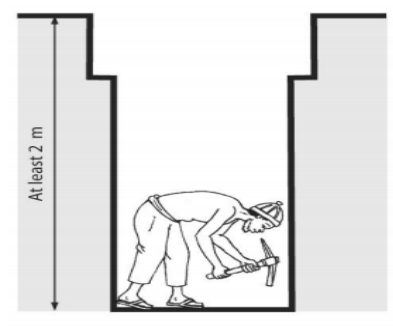

Figure.3.20 shape of Excavation

- Whatever type of soil, the sub foundation at the top 50cm of the pit must be lined with concrete brick or with rubble stones.

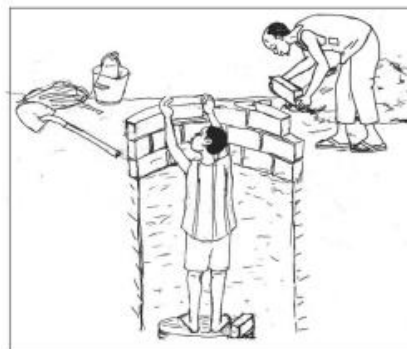

Figure.3.21a Erecting wall with stone



- The pit lining must be built above ground level to at least one line of concrete brick or rubble stone

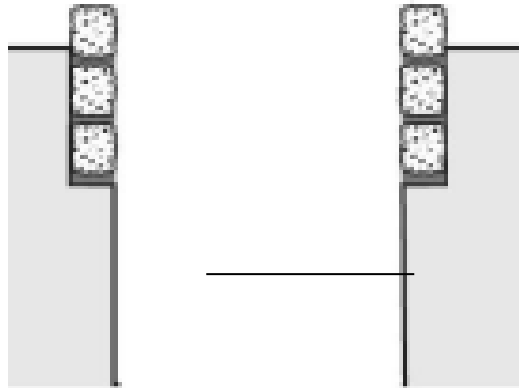

Figure.3.21b Erecting wall with mason

- In an area where the soil is stable it is not necessary to line the whole pit. Only the top 50cm will be lined

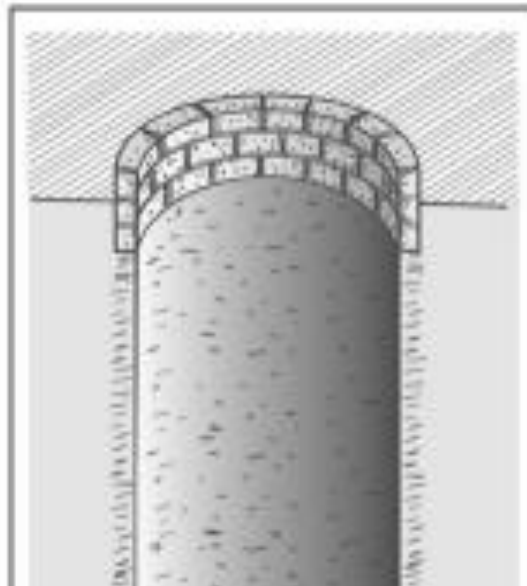

Figure.3.21c Erecting wall with mason

### Super structure Construction

Superstructure is part of the building, which is located above the grade beam. It is part of the building giving the service it is designed for.

Page 40 of 71	Ministry of Labor and Skills Author/Copyright	Block Production, Lay Masonry Unit and Finishing Work	Version - 1 May.2023
------------------	--	--	-------------------------

## Procedure of block wall construction

1. Read and interpreted the given drawing

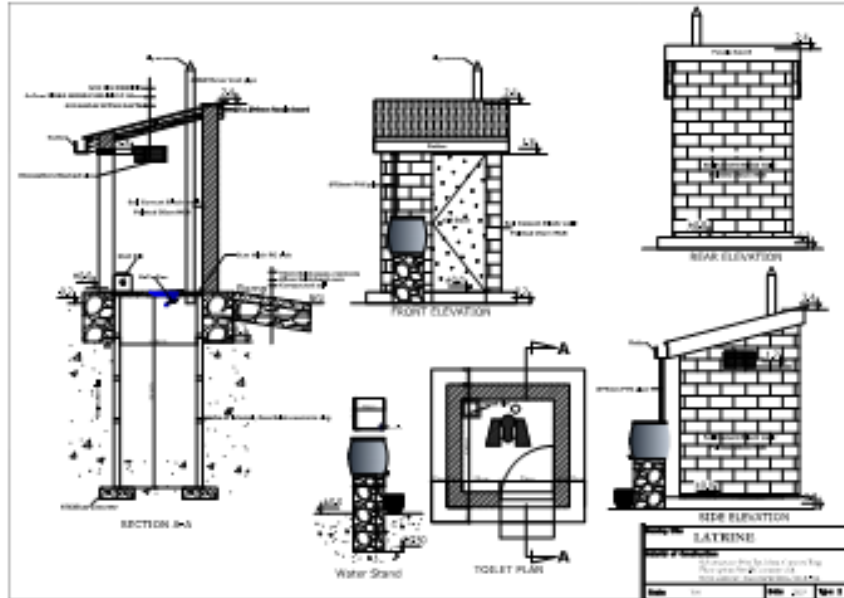

Figure: 3.22. Working drawing

2. Prepare all the necessary materials and equipment.
3. Mix mortar with the given ratio
4. Construct the wall starting from grade beam or masonry foundation.



Figure: 3.23. Grade Beam

5. Construct lintel, door and window opening and fix roof tying bar. A lintel is a horizontal structural members (beam) crossing over an opening. It is a small beam having a width equal to the width of the wall.



6. Carry out finishing work



7. Fixing Roof Structure









8. Apply roof covering



## Alternative materials for superstructure construction

Table: 3.1. Other alternative materials for superstructure construction

Structure Type With Illustration	Material Details	Advantage	Disadvantage
<p>Straw house</p> 	<p>Wall and roof materials: straw/thatch</p>	<ul style="list-style-type: none"> <li>• Low cost</li> <li>• Local materials</li> <li>• Skilled mason</li> <li>• Ventilation can be created at the top of the wall</li> </ul>	<ul style="list-style-type: none"> <li>• Temporary structure</li> <li>• Needs regular repair</li> <li>• Maintaining privacy is difficult if not constructed properly</li> <li>• Placing door latch might be difficult</li> </ul>
<p>Bamboo house</p> 	<p>Wall &amp; Roof materials: bamboo and straw/thatch</p>	<ul style="list-style-type: none"> <li>• Low cost</li> <li>• Local materials</li> <li>• Skilled mason not needed</li> <li>• Ventilation can be created at the top of the wall by making a space between the roof and the wall</li> <li>• Can be easily upgraded to clay or cement plastered wall structure</li> </ul>	<ul style="list-style-type: none"> <li>• Temporary structure</li> <li>• Roof material needs to be replaced periodically</li> <li>• Needs regular repair</li> <li>• Maintaining privacy is difficult if bamboo is not fixed properly</li> </ul>
<p>Clay-plastered house</p> 	<p>Wall materials: Bamboo/ straw wall plastered with clay on both sides. Roof materials straw/thatch</p>	<ul style="list-style-type: none"> <li>• Low cost</li> <li>• Local materials</li> <li>• Skilled mason not needed for construction</li> <li>• Privacy can be maintained</li> </ul>	<ul style="list-style-type: none"> <li>• Temporary structure</li> <li>• Roof material needs to be replaced periodically</li> <li>• Needs regular repair- clay will erode through contact with water</li> <li>• Wall may collapse if not constructed properly</li> </ul>

<p>Corrugated iron sheet</p> 	<p>Wall and roof materials: CGI sheet</p>	<ul style="list-style-type: none"> <li>• Semi-permanent structure</li> <li>• Privacy can be maintained</li> </ul>	<ul style="list-style-type: none"> <li>• Semi-skilled mason needed for construction</li> <li>• Toilet becomes hot during the summer and noisy during the monsoon rain</li> </ul>
<p>Wooden house</p> 	<p>Wall &amp; Roof materials:  Wood and CGI sheet</p>	<ul style="list-style-type: none"> <li>• Semi-permanent structure</li> <li>• Privacy can be maintained</li> </ul>	<ul style="list-style-type: none"> <li>• Semi-skilled mason needed for construction</li> <li>• Maintaining privacy is difficult if wood is not fixed properly</li> </ul>
<p>Stone house</p> 	<p>Wall &amp; Roof materials:  Stone and CGI sheet</p>	<ul style="list-style-type: none"> <li>• Permanent structure</li> <li>• Privacy can be maintained</li> <li>• Maintenance is easy</li> </ul>	<ul style="list-style-type: none"> <li>• Skilled mason needed for construction</li> <li>• Costly</li> </ul>
<p>Brick house</p> 	<p>Wall &amp; Roof materials:  Brick and CGI sheet</p>	<ul style="list-style-type: none"> <li>• Permanent structure</li> <li>• Can use both clay and cement mortar for laying bricks</li> <li>• Privacy can be maintained</li> <li>• Maintenance is easy</li> </ul>	<ul style="list-style-type: none"> <li>• Skilled mason needed for construction</li> <li>• Costly</li> </ul>

**Self-Check: 3**

**Part I: Multiple choices**

**Instruction:** Select the correct answer from the give choice. You are provided one minute for each question and each question carries 3 Points

1. One of the following hand tools is used to check Laid stone?
  - a) Sprit level
  - b) Straight edge
  - c) String & plumb bob
  - d) All of the above are correct
2. One of the following is the material used in constructing superstructure of toilet
  - a) Bamboo house
  - b) Clay-plastered house
  - c) Stone house
  - d) All are correct
3. One of the following hand tools is used to check vertical alignment of wall
  - a) Mason hammer
  - b) Trowel
  - c) Plumb bob
  - d) All of the above are correct
4. Which one of the following is the result of sand and cement & forms a pliable mass after mixing with water?
  - a) Mortar
  - b) Sand
  - c) Cement
  - d) All of the above are correct
5. Good mortar used for laying masonry walls consists of cement, sand and water in the correct proportions.
  - a) True
  - b) False
  - c) A& B
  - d) All of the above are correct

**Part II: Short Answer questions**

**Instruction:** write short answer for the given question. You are provided three minute for each question and each point has 5Points

1. List out Common types of Bond used in laying brick
2. Write the type of masonry in building construction

**Note: Satisfactory rating – above 75% points      Unsatisfactory - below 75% points**

You can ask you teacher for the copy of the correct answers.

Score = _____
Rating: _____

### Operation Sheet 3 Erecting Stone wall of 0.4m x 1m X 1m

**PURPOSE:** -To construct masonry wall properly according to the given slandered

Conditions or Situations for The Operations:-

- Ensure the working area hazard free
- Ensure Availability of appropriate clothes
  - Steel toe-capped boots.
  - Gloves
  - Safety glasses

**Equipment and Tools**

- |                       |                |
|-----------------------|----------------|
| • Builders shovel     | • Wire Brush   |
| • Measuring box       | • Sprite level |
| • Wheelbarrow/buckets | • Plump bob    |
| • Stone hammer        | • String       |

**Materials:** -

- ✓ Cement, Sand, Water and Stone

**Precautions:-**

- Wear working cloths which properly fit with your body
- Wear Mask
- Make working area hazard free.
- The water used for mixing should be free from all harmful organic substances
- Mixed materials must be laid at the required site within 30 minutes after adding water.

**Quality criteria:**

- The mortar should be mixed thoroughly to form a homogeneous mix.
- Use a plumb bob to check that all walls remain vertical.
- Ensure all joints are fully filled with mortar and all stones are fully embedded in mortar.
- The materials mix should be designed properly and should have all the ingredients in right proportions.

**Procedure:**

Preparation

- Identify job specifications
- Set out exactly the proposed structure
- Clean the foundation

Construction

- Use the largest and straightest tones on the ground and as corner stones
- Use two-faced shaped and squared stone for corners
- Lay stones on a mortar bed
- Leftover mortar should be cleaned
- The overlap of the stones should be minimum 10cm
- The joints thicker between 2.0-2.5cm but never less than 1.0 cm
- Curing of the stone.

<b>LAP Test: 3</b>	<b>Practical Demonstration</b>
--------------------	--------------------------------

Name: \_\_\_\_\_ Date: \_\_\_\_\_

Time started: \_\_\_\_\_ Time finished: \_\_\_\_\_

**Instructions:** Given necessary templates, tools and materials you are required to perform the following tasks within **1:30** hrs.

Task-3.1: Erect Stone wall of 0.4m x 1m X 1m



## Unit Four: Finishing work

This unit to provide trainees the necessary information regarding the following content coverage and topics:

- 4.1. Plastering
- 4.2. Pointing
- 4.3. Rendering
- 4.4. Painting application
- 4.5. Floor finishing

This guide will also assist trainees to attain the learning outcomes stated below. Specifically, upon completion of this learning guide, the trainees will be able to:

- Apply Plastering, Pointing, Rendering and painting application
- Carryout floor finishing

## 4.1. Plastering

- Plastering is the process of covering various surfaces of structure with plastic material such as cement mortar, lime mortar or composite mortar, to obtain an even, smooth, regular, clean and durable surface
- Provides base for receiving other decorative finishes like painting and white washing
- Cement and Sand Mortar is used to plaster concrete and cement stabilized blocks.
- Mortar batches shall be sufficient for use before partial setting occurs i.e. re-tempered mortar shall not be used.
- The components of cement mortar shall be cement-sand mix proportioned 1:3 for internal plastering and 1:2 for external plastering
- The components of mortar for final coat plastering shall be cement-sand Proportioned 1:2 by volume; the sand for the final coat shall be very finely graded.
- Do not use any mix after the initial set has taken place.
- Too much clay or fine material or sands of uniform particle size make for high shrinkage.
- Content of clay or fine material should not exceed 5%. More than 5% content mixes tend to develop a few large cracks; weaker mixes develop finer and distributed cracks.

### Application of Plastering

- Windows, doors frame and other joinery first fix items are in position and fixings.
- Working areas are clean, dry and free from obstruction.
- Construct Vertical or Horizontal guide before plastering.
- Apply cement – sand mix in one coat for a thickness up to 12mm and in two coats for a thickness up to 20mm. Thickness in excess of 20mm are not recommended. The final coat to a uniform thickness of between 3mm to 4mm.
- Generally, the finished surface should not deviate by more than 3mm in any consecutive 1.80m and be plumb. Actually the flatness of the plastered finish will depend up on the accuracy to which the background has been constructed.

Page 49 of 71	Ministry of Labor and Skills Author/Copyright	Block Production, Lay Masonry Unit and Finishing Work	Version - 1 May.2023
------------------	--	--	-------------------------

- Each coat of plaster shall be allowed to dry before applying the next coat. It is necessary to allow cement-sand plaster to dry for long enough for shrinkage to take place before the application of subsequent coats.
- Cure all coats periodically according to weather conditions and allow to set but not too dry before the next coats applied. Cement plastering shall be wetted for a minimum of seven days after application of the final coat.
- Traditionally most of the plasterers left the two coats surface finish rough so as receive the third coats. But when the final coat is applied using sieved fine sand, cracks will be developed since there are excess voids on it. Thus the second coat should be completed with good smooth finishing but not be fine smooth.
- The finished surface should have uniform thickness and texture.

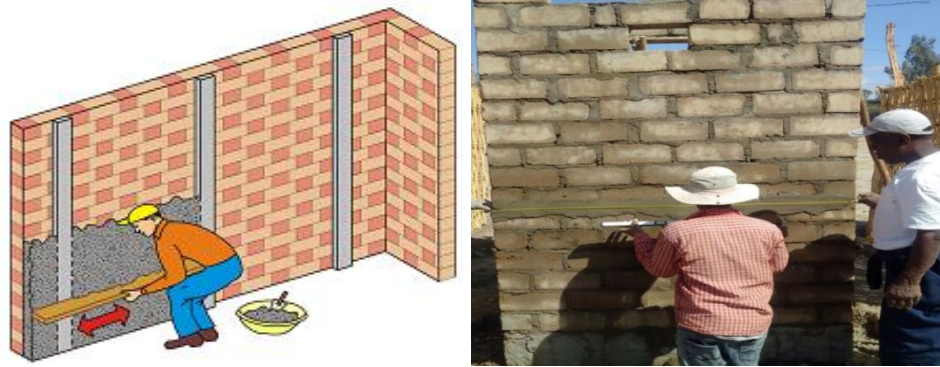
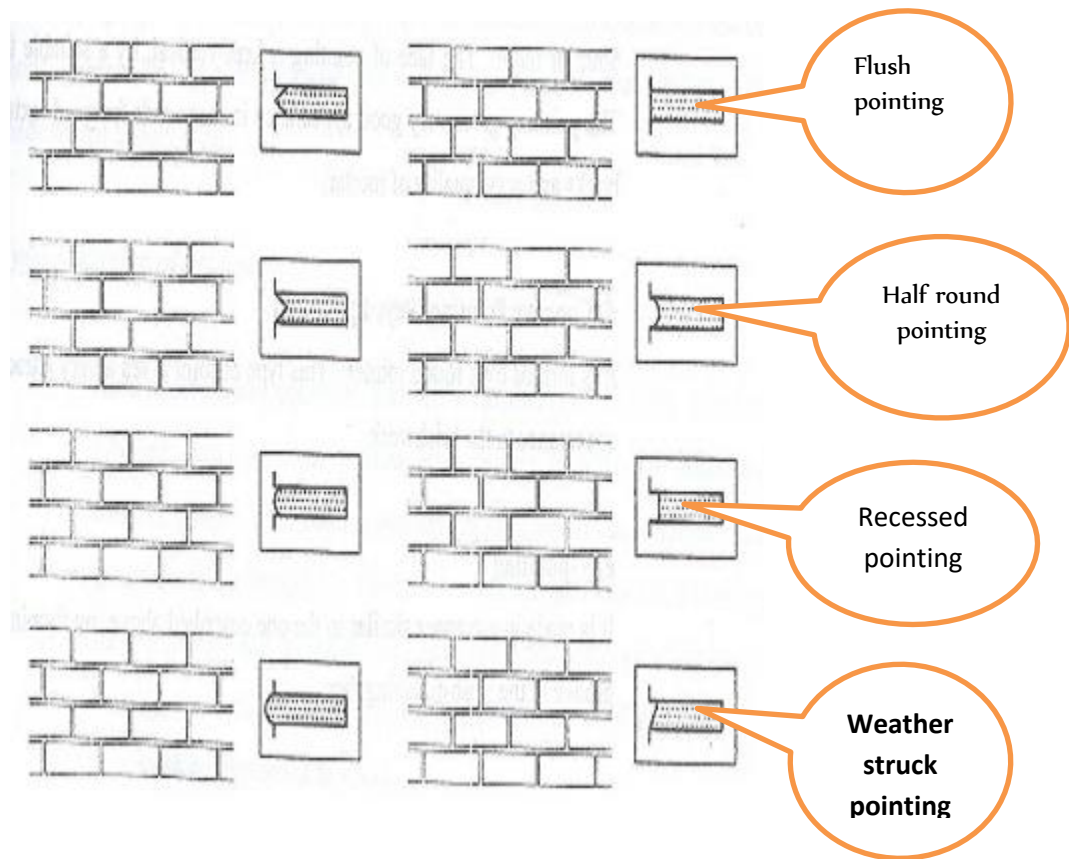

Figure-4.1: Plastering of wall with vertical & horizontal Guide

## 4.2. Pointing

- It is the process of sealing the masonry unit joints with good quality mortar.
- Initially joints are raked out to depth of 15 mm
- Suitable mix is refilled
- Provides water resistance and good appearance
- Mix proportion 1:2 (cement :fine aggregate)
- Can be flush or recess pointing
- Flush pointing: finished level and even to the wall
- Recess pointing: depth not less than 5mm.

- Pointed surface shall be cement dusted or cement pasted to form smooth surface and wetted for seven days.



### 4.3. Rendering

- The rendering process is used to coat exterior surfaces of buildings and contains a higher percentage of cement with its composition.
- Render is applied in several coats using a metal trowel or render machine. Screed battens are used to level out the render when applied.
- The top coat is applied more thinly.

#### There are two main reasons for house rendering:

- To protect the underlying house walls from weathering and rainwater penetration
- To provide an attractive appearance to the house



#### 4.4. Painting

Paints are coatings of fluid materials, applied as a final finish to all surfaces, such as walls, ceilings, wood work, metal work etc.

##### Objects of Painting

- Protect surface from weathering effects
- Protect the decay of wood and corrosion of metals
- Protect the decay of wood and corrosion of metals
- Provide decorative finish

##### Characteristics of a Good Paint

- Consistency – easy and free application with a brush, roller or spray
- Cheap in initial cost and prove economical in long run
- Shall not fade, nor change by external influences
- Should not show signs like brush marks, shrinkage marks, cracks, patches on drying

Oil paints are usually applied as a primer, undercoat and a finish coat. In the past oil paints were heavily relied on because of its durability and longevity on surfaces, however water-based paints are now at par. Known for their gloss and durability, oil paints stand for a rich finish, water-resistant properties and long-lasting abilities.

Page 52 of 71	Ministry of Labor and Skills Author/Copyright	Block Production, Lay Masonry Unit and Finishing Work	Version - 1 May.2023
------------------	--	--	-------------------------

## Selecting Painting Tools

### a) Paint Brush

Brush is an important tool for painting and available in various sizes and various shapes for different types of works. A wide range of brush sizes are available in market including 38mm 50mm, 60mm and 75mm. The quality of the brush used has a direct effect upon the quality of the finished job and the ease with which the paint is controlled and applied.



### b) Roller

A high quality roller frame and roller will give the best paint coverage and surface finish. A roller cover with the correct fabric should be choosing for the paint and surface being painted.



## 4.5. Floor Finishing

### Cement Screed

Screed is a thin layer of material that is placed on top of a concrete subfloor. Usually, screed consists of cement and sand, but where a more industrial version is required, coarse aggregates can be added to create a thicker layer.

## Procedure of Floor Screed

- i. Evaluate the surface of the base
- ii. Estimate materials used for screed
- iii. Preparing the base concrete
  - ✓ The base concrete should be prepared in such a way that it is left with a surface that is uniformly hard, clean, and free of dust, oil or other contamination.
  - ✓ Any screeds or toppings applied previously to the base should be removed completely.
  - ✓ All loose debris, dirt, and dust should be removed.
  - ✓ The surface of the base concrete should be reasonably accurate to the required level so that it is possible to place the screed or topping to a uniform thickness
- iv. Prepare the floor screed mixture
- v. Apply bonding agents such as water
- vi. Divide up your floor area.(If it is wide area)
- vii. Place the floor screed mixture



Figure: 4.4. Divide up your floor area & placing the floor screed mixture

- viii. Leveling a Floor With Screed



ix. Float Your Screed



x. Properly cure the screed

xi. Let the floor dry.

### Toilet Cement screed

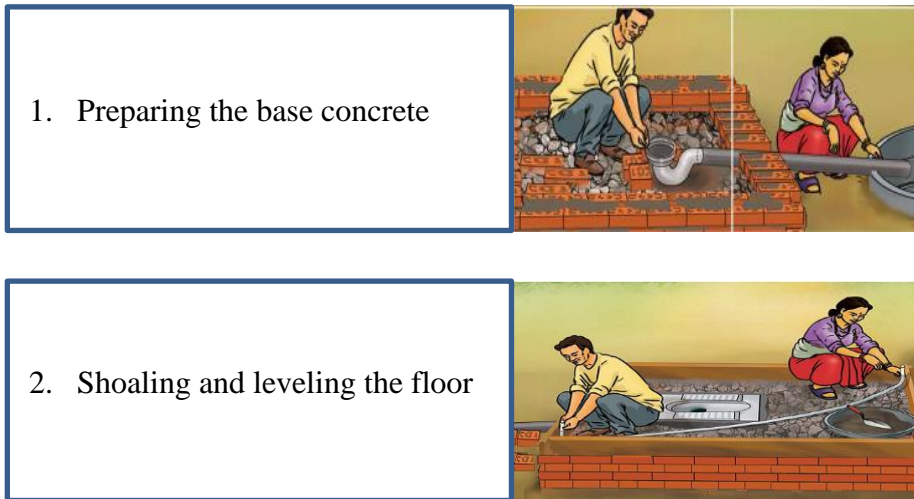

1. Preparing the base concrete

2. Shoring and leveling the floor

- ✓ After the joint seal has set, sand or clay should be filled underneath and to the side of the pan and compacted
- ✓ Brick or stone shoring should be done up to 5.1cm below the height of the pan
- ✓ A wooden frame of 7.6- 10.2cm height should be fixed on the shoring and outer surface of the brick wall
  - ✓ A mark should be made on one corner of the wooden frame to determine the thickness of the cement screed flooring; this should be 1.3cm above the pan
- ✓ A level pipe should be used to mark the other three corners of the wooden frame



### 3. Pan and siphon setting

- ✓ Pan should be placed on the neckline of the siphon /drain off
- ✓ The level of the pan should be checked by using a level pipe
- ✓ Water level should be maintained at least 2.5cm. above the bend of the
- ✓ The correct position of the pan and siphon, and water level is shown in below figure

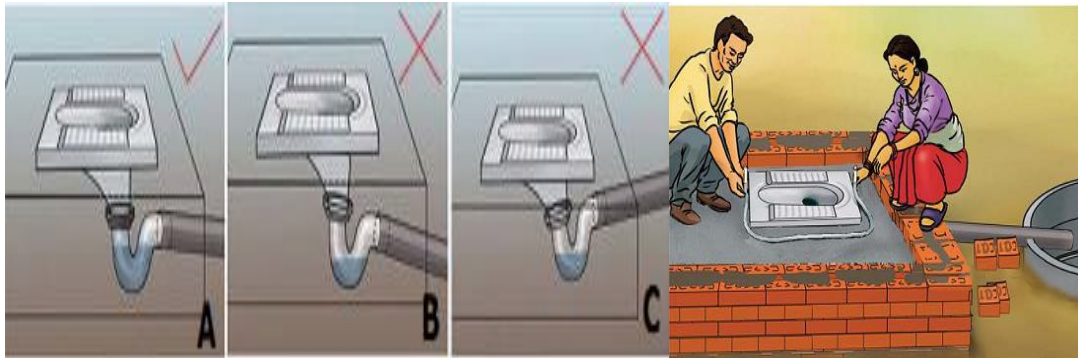

Figure-4.5: The position of the pan and siphon, check by water level

### 4. Floor concreting and finishing

- ✓ Concrete of 1:2:4 cement, sand and gravel should be filled up to the mark on the wooden frame and level with the pan
- ✓ The concrete should be compacted followed by smooth finishing with 1:1 cement, sand paste.
- ✓ The slope of the floor should be maintained towards the pan from all directions (as shown in illustration below)

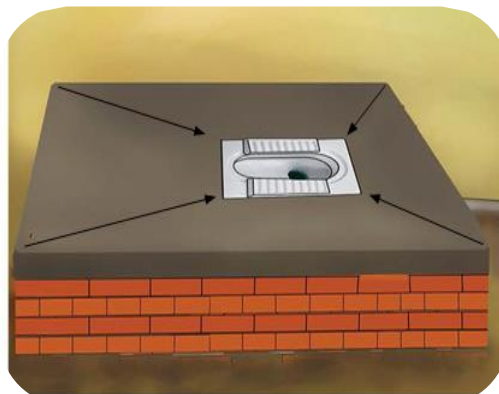

Figure: The slope of the floor

## Toilet Cement screed in wooden slabs

- Make sure the floor have a sound structure that is well reinforced with wood planks or logs and can support the additional weight
- Remove the existing floor clear the mud floor in the owner’s preference dimension until the reinforcement wooden plank is uncovered,
- Clean dust and any alien material from the floor
- Make sure the wood plank does not have openings. If there is an opening, use plastic sheet to cover the floor.
- Put the wood framework sized as per the demand of the customer and floor size can be 100 cm X 100 cm & make sure the framework is leveled
- If the required concert fill is high put stones as hard core. Make sure the SATO pan is placed leveled
- Start filling the framework with concrete Mix (1:2:3) ratio
- Put the foot pad mold reversed to make footing pad and fill with concrete. Make sure the SATO pan is leveled the closure is working properly by pouring water and pure trowel
- Curing, Water the slab so that we can get the required strength. Cure the slab by pouring water three times a day for the first seven days, until it becomes wet uniformly and once per day for the next fourteen days.

## Earth Enable floor solution

### 1) Floor Improvement Solution

An earthen floor is an ancient flooring technique that has been revived and modernized in recent years. Earthen floors are made of natural materials sourced locally (gravel, laterite, sand, clay, and water). It eliminates unsanitary dirt floors and provides affordable, sanitary flooring that can be washed, cleaned, and used to create a healthy home environment for millions of people.

### 2) Benefits of Earth Enable floor solution

Earth enable is a floor made from locally found compressed earth and stabilized with a layer of oil. The floors are designed as a healthier alternative to dirt floors while being more affordable

Page 57 of 71	Ministry of Labor and Skills Author/Copyright	Block Production, Lay Masonry Unit and Finishing Work	Version - 1 May.2023
------------------	--	--	-------------------------

than concrete. It is also an environmentally friendly flooring solution. The floor solution has the following known benefits.

### **Health**

Healthy floors have been shown to reduce the incidence of childhood diarrhea by 49% and parasitic infections by 78%. Dirt floors have been shown to harbor parasites, bacteria, and pathogens dangerous to children and the adults living in these homes. More than 1.8 million people are killed by diarrhea alone each year. The risks of diarrhea, malnutrition, asthma and pneumonia have all been shown to be reduced drastically when a home environment does not have a dirt floor.

### **Affordability**

A healthy Earth enable floor is 75% cheaper than a concrete floor, meaning it provides all of the benefits of a concrete floor at just a fraction of the price.

### **Jobs**

Masons learn how to create and install an earthen floor. Then, these masons can go out and become income-generating entrepreneurs utilizing their new skills.

### **Sustainability**

Utilizing natural materials and green building techniques allows minimizing the carbon footprint. Cement production is responsible for 5% of total global carbon emissions and is incredibly energy intensive to produce. Earthen floors have 90% less embedded energy and are structurally strong, waterproof, and abrasion resistant.

## **3) Construction steps**

Earthen floors utilize layers to make them as strong and resilient as possible. The first and second layers can be grouped as one but relaxed for better understanding of the steps.

### **Layer 1: Gravel (stone) layer**

Remove existing floor especially loose soils and cow dung finishing. This layer is made of coarser materials to bring strong base for coming layers. Ensuring stones are well laid down and leveling is achieved, and then proceeds with filling gaps with small stones and sand. Stones will

Page 58 of 71	Ministry of Labor and Skills Author/Copyright	Block Production, Lay Masonry Unit and Finishing Work	Version - 1 May.2023
------------------	--	--	-------------------------

be used in different sizes, starting from big with small ones on top. If this layer is omitted, the base needs to be compacted and leveled before proceeding to next step.



### Layer 2: Laterite layer

Made of the same earthen materials, it binds with the coarse laterite. The sand will need to be sieved before use so that coarse retained will be mixed with local clay to fill gaps between small stones. Both first and second layers are compacted manually.



### Layer 3: Fine Earthen Mix

Clay will need to be processed into a fine powder. Both fine sand and clay needs to be sieved. Then troweled flat/ polished to form smooth and beautiful top layer. The best proportion is 5-part sand and 2-part clay. These will avoid cracks. These layer needs to be applied when the first two layers are dried to allow the next step.



#### Layer 4: Oil

The floor is then sealed by a layer of drying oil that polymerizes as it dries to form a waterproof and plastic-like resin on top. The oil permeates the fine earthen mix, and this is also the layer that gives the floor its shine, makes it easy to clean and incredibly durable. The oil is applied in three layers and will take two days to apply. The best thickness of these layers is  $0.15\text{lt/m}^2$  for first,  $0.12\text{lt/m}^2$  for second and  $0.03\text{lt/m}^2$  for final layer. The final layer needs to be applied next/second day. When colored varnish/oil is applied, it will be on the second layer. These layer needs to be applied when the third layer is dried.

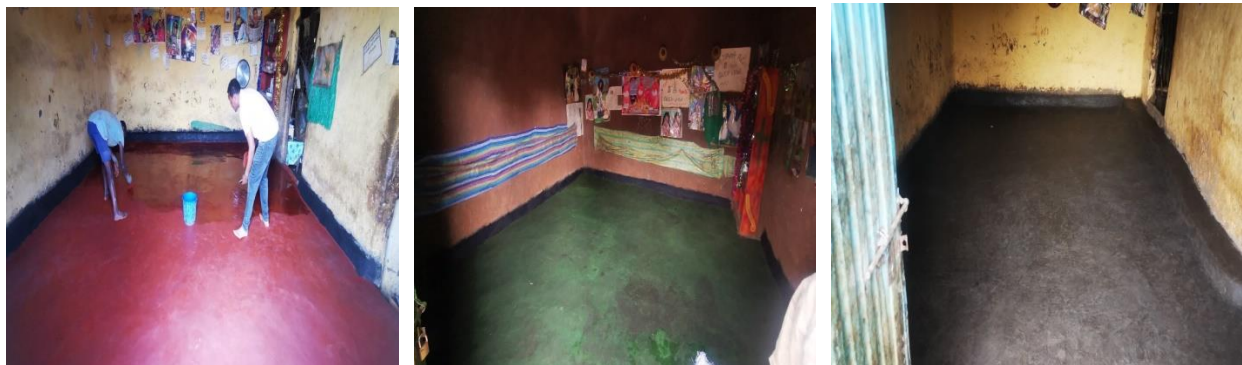

The total days the floor takes to be completed will varies from house to house, and toilet to toilet. The drying process is heavily dictated by ventilation and humidity. It is roughly predicted from prototype is that the floor will take between 25-40 days to be completed. Whenever it is possible, build rooms at different time-phasing and avoid any action that can harm the final quality product. Placing wood or other on top of the floor to avoid touching the floor is a good option.



### Layer 5: Training

After the floor is improved, the customers need to be training and instruction needs to be given to get longer service from the changes.

1. To avoid putting sharp objects like chair and table feet that will have penetrating effect on the floor. Use thick cartoon or similar materials underneath this foots.
2. Don't leave any damages untouched. It is always good to made correction whenever defects are observed before the issue aggravates and difficult to be corrected easily.
3. Don't leave splashed water and liquids unattended. Clean with towel
4. Clean the improved floors with broom once a week.
5. Avoid entering the house with dirty shoes.



**Self-Check: 4**

**Part I: Multiple choices**

**Instruction:** Select the correct answer from the give choices. You are provided one minute for each question and each question carries 3 Points.

1. One of the following is true about plastering
  - a) Each coat of plaster shall be allowed to dry before applying the next coat
  - b) Surface to be plastered shall be thoroughly clean before plastering
  - c) Working areas are clean, dry and free from obstruction before plastering
  - d) All of the above are true
2. . One of the following tools is used to apply paining
 

a) Claw hammers	c) Sprite level
b) Brush	d) None of the above

**Part II: Short Answer questions**

**Instruction:** write short answer for the given question. You are provided three minute for each question and each point has 5Points

1. What is pointing?
2. What is the advantage of plastering external wall of building?
3. What is the benefit of earth enable flooring solution?

**Note: Satisfactory rating – above 75% points      Unsatisfactory - below 75% points**

You can ask you teacher for the copy of the correct answers.

**Answer Sheet**

Score = _____
Rating: _____

## Unit Five: Roof structures and sheet coverings

This unit to provide trainees the necessary information regarding the following content coverage and topics:

- 5.1. Setting out of roof members
- 5.2. Roof support installation
- 5.3. Roof covering installation

This guide will also assist trainees to attain the learning outcomes stated below. Specifically, upon completion of this learning guide, the trainees will be able to:

- Sett out of roof members
- Apply Roof support installation
- Apply Roof covering installation



## 5.1. Setting out of roof members

A roof is defined as the upper most part of the building provided as a structural covering, to protect the building from external weather exposure such as rain, sun, wind, etc. Basically, a roof consists of structural elements, which support roof coverings. .

### Requirements of a good roof

- 1) It should have adequate strength and stability to carry the dead and live loads.
- 2) It should effectively protect the building against rain, sun, wind, etc. and it should be durable against the adverse effects of these agencies.
- 3) It should be water proof and should have efficient drainage arrangements.
- 4) It should provide adequate thermal insulation.
- 5) It should be fire resistant.
- 6) It should provide adequate insulation against sound.
- 7) It should be acceptable cost.

The general types of roofs based on shapes may be classified as follows:

1. Pitched or Slopping roofs
2. Flat roofs or terraced roofs, and
3. Curved roofs.

The selection of the type of roof depends upon:

- Shape or plan of the building
- Climatic conditions of the area
- Type of construction materials available.

#### **Pitched roofs:**

- Have slopping top surfaces.
- Are suitable in those areas where rainfall/snow fall is very heavy
- Use to cover satisfactorily those buildings with limited width and simple shape

#### **Flat roofs:**

- Considered suitable for buildings in plains or in hot regions where rainfall is moderate and snow fall is not there.
- Are equally applicable to buildings of any shape and size.

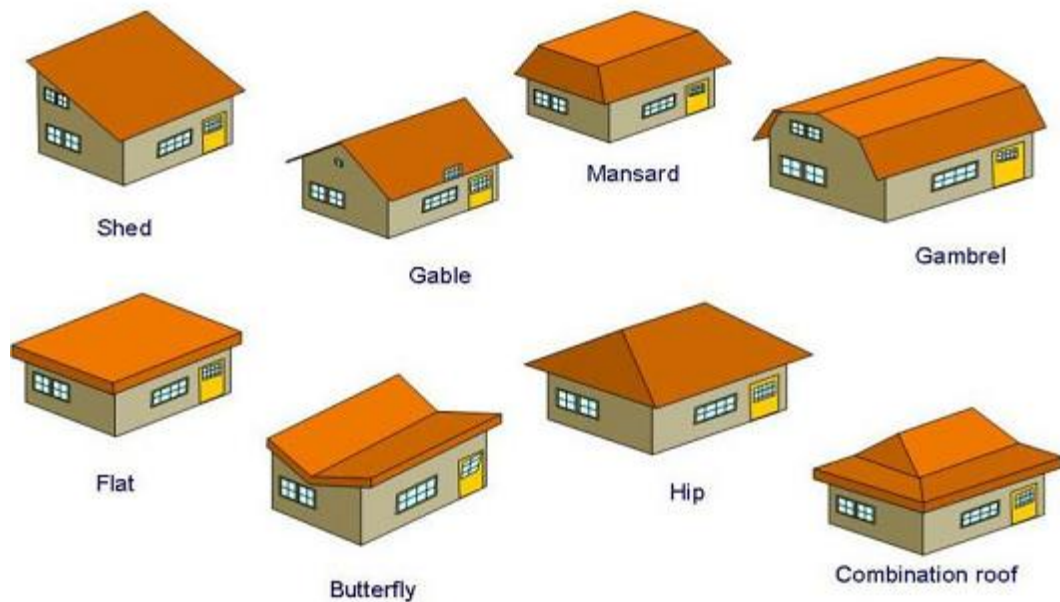

Figure-5.1: Forms of sloping roofs

## 5.2. Roof support installation

A truss is a structure with a straight pieces forming triangle to support a load. The members of the triangle are placed under tension and compression but do not bend. They are vertical member, horizontal member and diagonal members.

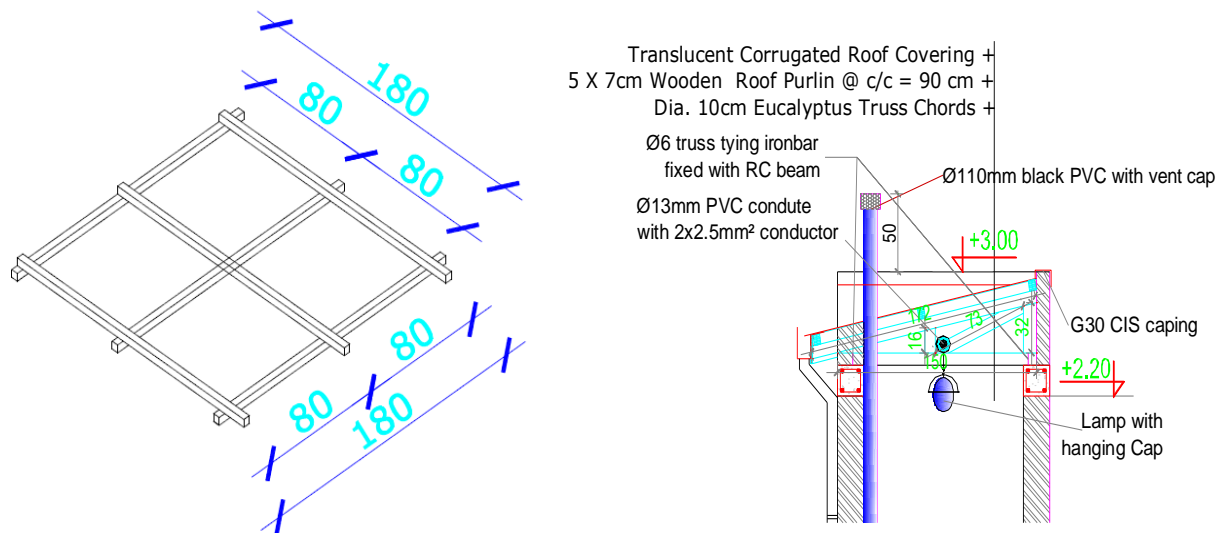

Fig. 5.1. Roof Structure

### 5.3. Roof covering installation

#### Roof Covering Materials

- Roof covering material is provided to protect the surface of the roof structure.
- It also prevents heat, moisture, rain-water, etc. to enter into the building.
- The roof covering must be strong enough to carry some occasional light loads.
- There are various types of roof covering materials available for use under varying conditions.

#### Types of Roof Covering Materials

##### Thatch Roof Covering

- It is one of the most ancient types of roof covering material and mainly used in village areas.
- Thatch roof cover is suitable for rural buildings mainly because the cost is very low
- Thatch is abundantly available in rural regions.
- Well-constructed thatch roof is about 15-25cm thick in order to check the penetration of rain water.
- Thatch is of either straw or reed.



Fig.5.2. Thatch Roof

### Galvanized Corrugated Iron sheet

- It is very durable, light and fire proof.
- It is usually manufactured in sheets which are corrugated or bent in a series of parallel depressions from end to end.
- These corrugations also help in draining the water from top of the roof.
- The purpose of galvanizing the iron sheet with zinc is to protect it from rusting in wet weather.
- The gauge indicates the thickness G-24=0.549mm, G-26=0.457mm, G-28=0.376mm, G-30=0.315mm, G-32=0.274mm and G-35=0.2mm.



Fig.5.3. Galvanized Corrugated Iron sheet

**Self-Check: 5**

**Part I: Multiple choices**

**Instruction:** Select the correct answer from the give choices. You are provided one minute for each question and each question carries 3 Points

1. One of the following is the advantage of roof covering.
  - a) It protect the building from rain,
  - b) It protect the building from sun
  - c) It protect the building from wind
  - d) All of the above are correct
  
2. One of the following is the type of roof structure used in the area where there is less rain fail climate.
  - a) Pitch roof
  - b) Flat roof
  - c) Shells and folded plates
  - d) All of the above are correct
  
3. One of the following roof covering is the most ancient types of roof covering material and is mainly used in village areas.
  - a) Galvanized Corrugated Iron sheet
  - b) EGA
  - c) Thatch Roof Covering
  - d) All of the above are correct

**Part II: Short Answer questions**

**Instruction:** write short answer for the given question. You are provided three minute for each question and each point has 5Points

1. What is the indication of gauge in corrugated iron sheet?
2. Write at least three points about the requirements of a good roof

**Note:** Satisfactory rating above 75% points Unsatisfactory - below 75% points

You can ask you teacher for the copy of the correct answers.

**Answer Sheet**

Score = \_\_\_\_\_

Rating: \_\_\_\_\_

## Bibliography

MOH manual

ESC D3.301

TVET SCW Level II TTLM August, 2022 (Produce Bricks and Blocks and lay masonry unit)

Stabilized Earth Block Manufacture in Sudan (Doctor E.A. Adam in collaboration with Professor A.R.A. Agib)

BATCODA-Technical Specification

## Participants of This Module (Training Material) Preparation

No	Name	Qualification (Level)	Field of Study	Organization/ Institution	Mobile number	E-mail
1	Andualem Abebayehu	MSc	Hydraulics and Water Resource Engineering	Debark PTC	0982095105	andualemabebayhu@gmail.com
2	Mesfin Wondimu	BSc	Construction Technology and Management	Aleta Wondo PTC	0916981613	mesfinwondimu@gmail.com
3	Girema Moges	BSc	Civil Engineering	Wolayita PTC	0911530068	girmamoges@gmail.com
4	Dagim Fekadu	MSc	Construction Technology and Management	Ambo PTC	0910140914	dag.astu.2005@gmail.com
5	Solomon Tadesse	BSc	Construction Technology and Management	GWPTC	0921414347	soletadss@gmail.com
6	Esmael Mohammed	BSc	Water Work construction technology	Kombolcha PTC	0915543225	Bad9565@gmail.com
7	Desalegn Alemu	BSc	Construction Technology and Management	Woliso PTC	0926771683	desalgnalen@gmail.com
8	Tesfaye Assegidew	MSc	Construction Technology and Management	Butajira PTC	0913442444	tesfayessegidew@gmail.com
9	Mulualem Misganaw	BSc	PLSC	MOLS	0910463950	mulu9192@gmail.com
10	Bacha Kitesa	MPH, MA	Environmental Health since, public health, Project Management	PSI	0910757797	bachakitesa@gmail.com
11	Mesfin Habtemariam	MA, BSc	Civil Engineering	PSI	0911124992	mesfinhabtemariam@gmail.com
12	Fisum G/Egizeebiher	MPH	Environmental Health Science	PSI	0913222354	fegziabher@psiet.org
13	Ziyade Ahmed	MPH	Environmental Health Science	MOH	0916586603	
14	Wondayehu Wube	BSc, MPH	Environmental Health Science	MOH	0972651005	wondayehuwube@gmail.com