

Manufacturing Sanitation Production and Latrine Construction

Advanced Short-Term Training

Based on May 2023, Curriculum Version I



Module Title: - Installation of sewerage system, water supply line
and sanitary appliance

Module code: EISPLI1 06 05 23

Nominal duration: - 16 Hours

Prepared by: - Ministry of Labor and Skill

May, 2023

Addis Ababa, Ethiopian

Page 1 of 41	Ministry of Labor and Skills Author/Copyright	Installation of sewerage system, water supply line and sanitary appliance	Version -1
			May, 2023

Table of Contents

Acknowledgement	3
Introduction to the Module	4
Unit One: Sanitary Material, Tools, and Equipment's	5
1.1. Types of pipes, fittings, and valves	6
Fittings and valves	7
1.2. Sanitary Tools and Equipment	13
Unit Two: - Installation of Sewerage Line	16
2.1. Parts of Sewerage Line.....	17
2.2. Ventilation and Trap.....	18
2.3. Layout of Sewerage Point	19
2.4. Connection Technique.....	20
Unit Three: Installation of Water Supply Line component	25
3.1. Water Supply System.....	26
3.2. Layout of Water Supply Line.....	28
3.3. Connection Techniques	28
3.4. Types of sanitary appliances	32
References books	39
Participants of This Module (Training Material) Preparation	40

Page 2 of 41	Ministry of Labor and Skills Author/Copyright	Installation of sewerage system, water supply line and sanitary appliance	Version -1
			May, 2023

Acknowledgement

The Ministry of Labor and skill would like to extend its gratitude to MoH, One WASH national Program, USAID, PSI, Regional Labor, and skill/training Bureaus, TVT College Deans, Instructors, and industry experts for their financial and technical support of Manufacturing Sanitation Product and Latrine Construction training module. Finally, MOLS extends its gratitude to the following instructors and experts who contributed to the development of curriculum.

Mulualem Misganaw	Senior Expert /TVT Sector	MOLS
Mesfin Habtemariam (MSc)	Engineering Technical Manager	PSI/TWASH
Bacha Kitesa (MpH, MA)	WASH Capacity Development Manager	PSI/TWASH
Fisum G/Egizebiher (BSc)	WASH Business Development Manager	PSI/TWASH
Dagim Demirew	Associate Director, WASH Business development	PSI/TWASH
Ziyad Ahmed (MpH)	Senior Expert	MOH
Wondayehu Wube (MpH)	Senior Expert	MOH
Andualem Abebayhu (MSC)	Instructor	Debark PTC
Mesfin Wondimu (BSC)	Instructor	AletaWondo PTC
Girema Moges(BSc)	Instructor	Wolayita PTC
Dagim Fekadu (MSc)	Instructor	Ambo PTC
Solomon Tadese(BSc)	Instructor	GWPTC
Esmael Mohammed (BSc)	Instructor	Kombolcha PTC
Desalegn Alemu (Bsc)	Instructor	Woliso PTC
Tesfaye Assegidew (MSc)	Instructor	Butajira PTC

Introduction to the Module

This module consists of identifying Sanitary material, tools and equipment's, install sewerage system, install water supply system and fix sanitary components besides having a thorough understanding of the mechanisms required for performing various tasks.

This course covers the units.

- Sanitary material, tools, and equipment's
- Install sewerage system.
- Install water supply system and sanitary components.

Learning Objective of the Module

- Identify sanitary material, tools, and equipment's.
- Install sewerage system.
- Install water supply system and sanitary components.

Module Instruction

For effective use these modules trainees are expected to follow the following module instruction:

- Read the information written in each unit.
- Accomplish the Self-checks at the end of each unit.
- Perform Operation Sheets which were provided at the end of units.
- Do the “LAP test” giver at the end of each unit and
- Read the identified reference book for Examples and exercise.

Page 4 of 41	Ministry of Labor and Skills Author/Copyright	Installation of sewerage system, water supply line and sanitary appliance	Version -1
			May, 2023

Unit One: Sanitary Material, Tools, and Equipment's

This unit is developed to provide trainees the necessary information regarding the following content coverage and topics: -

- 1.1 Types of pipes, fittings, and valves
- 1.2 Sanitary tools and equipment

This unit will also assist trainer to attain the learning outcomes stated below.

Specifically, upon completion of this learning guide, trainees will be able to: -

- Identify types of pipe, fittings and valves
- Identify sanitary tools and equipment.

Page 5 of 41	Ministry of Labor and Skills Author/Copyright	Installation of sewerage system, water supply line and sanitary appliance	Version -1
			May, 2023

1.1. Types of pipes, fittings, and valves

Types of pipes

The potable water supply, sanitary sewerage and vent systems are constructed using pipe, fittings, valves, and meters.

The three main categories of pipes used for Plumbing installation.

- Metallic pipes
- Cement pipes
- Plastic pipes.

The choice of the kind of pipe to be installed depends upon the following considerations:





- Quality and durability
- Resistance to external and internal contact with foreign matters.
- Resistance to acid waste and other chemical elements that will pass into it.
- Cost of materials and labor.

Common types of plumbing piping materials are: -

- PVC (Polyvinyl Chloride).
- PPR pipe (polypropylene random pipe)
- Galvanized iron
- HDPE pipe (High density polythene)

Page 6 of 41	Ministry of Labor and Skills Author/Copyright	Installation of sewerage system, water supply line and sanitary appliance	Version -1
			May, 2023

Table-1: Types of Pipes

Name	Using of pipe	Pitcher
Polyvinyl Chloride (PVC) pipe	This type of pipe has a wide variety of plumbing uses for sewerage and drainage pipe to water mains. PVC pipes are joined by using PVC glue.	
PPR (polypropylene random pipe)	PPR pipes are designed for Hot and Cold-water supply and heating applications, and it is suitable for different applications	
HDPE Pipes (High density polythene)	HDPE is a polyethylene thermoplastic made from petroleum. HDPE pipes are best preferred for industrial, Domestic and irrigation purpose.	
Galvanized Iron	GI pipes are made of steel and use for water supply systems. It is joined using threaded galvanized iron fittings.	

Fittings and valves

Fitting:-is used in pipe systems to connect straight sections of pipe or tube.





Valve: -Valve is a fitting installed by plumbers on a piping system to control the flow of fluid within that system in one or more of the following ways.





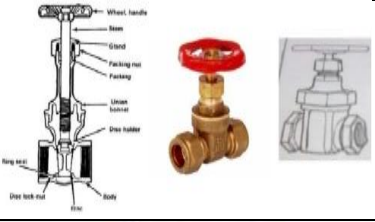



- To turn the flow on
- To turn the flow off

Generally, the different types of valve and fittings stated below; -

Page 7 of 41	Ministry of Labor and Skills Author/Copyright	Installation of sewerage system, water supply line and sanitary appliance	Version -1
			May, 2023

Table-2: Types of GIS fittings and valves

Name	Using fitting	Pitcher
Gate valve	A gate valve is the most common valve for water supply system to control flow of water	
Check valve/No-return Valve. /Reflux Valve	Permit water to flow in one direction only. They are used in pump suction lines to prevent loss of water from the line when the pumped is stopped.	
Ball Valve	A valve in which the flow of liquid is controlled by a rotating drilled ball that fits tightly against a resilient or flexible seat in the valve body.	
Angle Valve	Angle Valves are used for individual plumbing fixture control such as lavatory, water closet etc. Its inlet and outlet openings are at 90° angle to one another.	
Float Valve	A valve used to control the water level in a tank or other container. It is operated by a float valve and the closing or opening which is dependent on the rise and fall of the float valve.	

Hose Bib/Water Tape/	Taps are usually used at the end of a pipeline for draw off purposes.	
GIS Elbow	It used to change the angle or direction of the pipe run. The most common elbows come in 90 degree and 45 degree turns.	
GIS Tee	An internally threaded fitting that is used to distribute pipes with a "T" mode.	
GSI Coupling	It is an extensional fitting. used to join two straight pieces of pipe at the same diameter.	
GSI Reducer	It used to change the diameter of pipe	
GSI Bush Reducer	It used to change the diameter of pipe. It has female and male thread	
Union	A fitting used for joining the ends of two pipes neither of which can be turned.	
Nipple	A short piece of pipe with outside threads used for connecting pipes or fittings in threaded joints.	

PPR fittings and valves



Different HDPE fittings



Different PVC fittings





1.2. Sanitary Tools and Equipment

There are several types of tools used by a plumber. They are called hand tools, in general, used to ease the work and accelerates the process, improves quality of work significantly.

Requirements for tools selection are:

- The material quality strength and durability
- Simple in adjust/install.
- Simple in use
- Simple in maintenance
- Economical

The table below shows the common hand tools used for sanitary piping system.

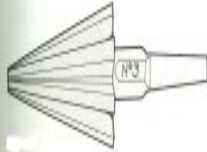
Name	Use of hand tools	View
Hack saw	It is a tool used to cut pipes and other metals.	
Pipe cutter	It is used to cut pipes at right angle. It performs the job much easier than a hack saw.	
Plastic tubing cutter	Used to cut flexible plastic pipes quickly. Do a fast, neat job of cutting can cut PPR pipe.	
Reamer	It is used to clear burrs at the end of cut pipe, the tools used for these purposes.	

Dies stock	A threading die is used for making threads in a pipe where it is to be joined with another pipe.	
Bench vice	A vice is a tool used for holding an object for various tasks like filing, chipping, sawing, threading, tapping, bending, etc	
Pipe vice	It is a tool used for holding a pipe for carrying out assembly, disassembly, threading, cutting, etc.	
Adjustable wrench	This type of wrench is used to loosen or tighten the nuts and bolts of any odd and regular sizes. It is used for tightening and loosening valves, cocks, geysers, flexible pipes, etc.	
PPR Welder machine	It is an ordinary PPR Pipe Welding Machine , suitable in welding various pipes, like PPR pipes equipped 6 molds of the minimum size within 20 mm...	
Pressure test pump	It is used for pressure and leak testing on testing pump, is designed to pressure test all types of fluid system for leaks	

Self-Check-1

Part I: Give short answer for the following questions.

1. Identify plumbing hand tools.
2. List types of plumbing materials.

Part II: Match the following questions.

Column A

1. Pipe wrench
2. Hacksaw
3. Diestock
4. Bench vice

Column B

- a) Holding tool
- b) Threading tool
- c) Cutting tool
- d) Pipe bending tool.

Part-III: -Choose the correct answer.

1. Which materials are used to install for disposal line?
 - a) PPR pipe
 - b) PVC pipe
 - c) GSI pipe
 - d) All
2. Which material is used to install water supply line?
 - a) PPR pipe
 - b) GSI pipe
 - c) HDP pipe
 - d) all
 - e) Non
3. Which of the following is differing from the others?
 - a) Die stock.
 - b) PPR cutter
 - c) Hack saw
 - d) Pipe cutter

Unit Two: - Installation of Sewerage Line

This unit is developed to provide trainers the necessary information regarding the following content coverage and topics: -

- 1.1. Parts of sewerage line
- 1.2. Ventilation and trap
- 1.3. Layout of sewerage point
- 1.4. Connection technique

This unit will also assist trainers to attain the learning outcomes stated below.

Specifically, upon completion of this learning guide, trainees will be able to: -

- Identify parts of sewerage line
- Explain the purpose of ventilation and trap.
- Practice the lay out of sewerage.
- Identify connection technique.

Page 16 of 41	Ministry of Labor and Skills Author/Copyright	Installation of sewerage system, water supply line and sanitary appliance	Version -1
			May, 2023

2.1. Parts of Sewerage Line

Parts of Sewer System [the ultimate guide] are: -

- Traps
- Branch Drain Lines
- Soil Stacks and Ventilation
- The Clean-Out
- Main Drain Line
- Sewer line.

Page 17 of 41	Ministry of Labor and Skills Author/Copyright	Installation of sewerage system, water supply line and sanitary appliance	Version -1
			May, 2023

2.2. Ventilation and Trap

Vent System: -is a pipe or pipes installed to provide a flow of air to or from drainage or to provide a circulation of air within such system to protect trap seals siphoning and back pressure.



Fig-1: Vent

Traps: - are defined as fittings at the end of soil pipes of waste pipes to prevent foul gases coming out of the soil pipe/ waste pipe. The trap seal used to prevent foul gas come into the building.

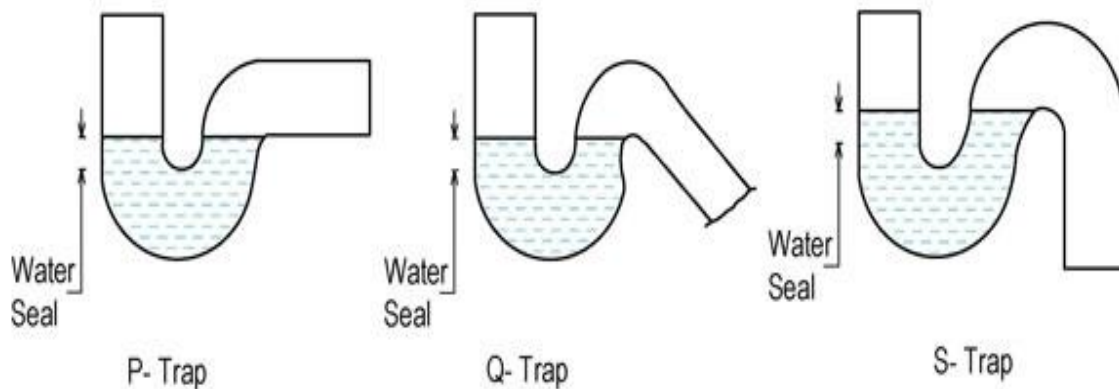

Fig-2: Traps according to shapes

Page 18 of 41	Ministry of Labor and Skills Author/Copyright	Installation of sewerage system, water supply line and sanitary appliance	Version -1
			May, 2023

The column of water that is retained between the overflow and the dip of the trap is called **Trap Seal**. It is sometimes referred to as **Water Seal**.

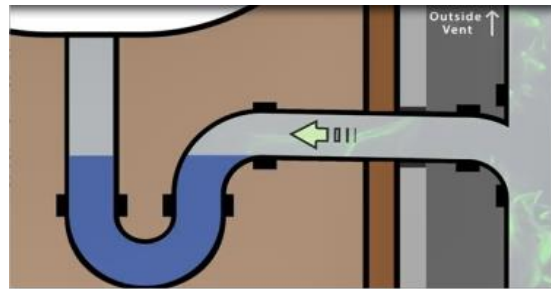

Fig-3: Water seal

2.3. Layout of Sewerage Point

A plumbing plan or a plumbing drawing is a technical overview of the system that shows the piping of either in supplying water to different parts of the building or to remove and discharge human waste and other substances out of building. This layout plan view drawing which shows the plumbing system, and it is generally traced from the floor plan.

Plumbing diagram depicts a complicated network of water supply pipes, drainpipes, vent pipes, and other components. Because plumbing is a complex system that is one of the most expensive to repair or install in a home, it is important to understand how it works.

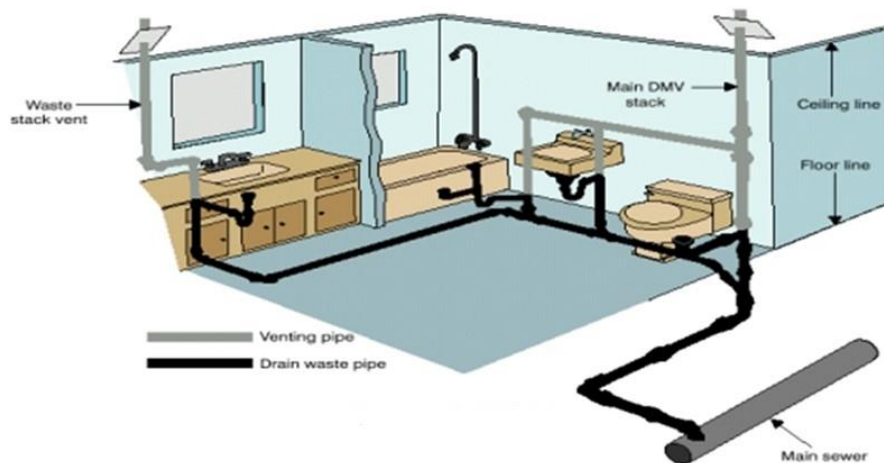

Fig-4: Sewerage line

Page 19 of 41	Ministry of Labor and Skills Author/Copyright	Installation of sewerage system, water supply line and sanitary appliance	Version -1
			May, 2023

2.4. Connection Technique

Wastewater/ sewage system: -a system that takes out used water and sewage. Also let's air in and waste gases out. The amount of liquid that can flow from a fixture is the basis for determining the size of drain-waste piping. Generally, install soil stack, waste lines, vents, and traps are very important works in sanitary installation work.

General Conditions for Waste Pipe Installations

- The right choice of materials
- Conservative use of fittings
- Right location of clean outs.
- The right slope or grade of the pipeline.
- The manner of joining the pipes.
- The right size of the pipe.

The following are recommendations for good connection: -: -

- Do not use fittings of short radius on a vertical to horizontal directions or horizontal to horizontal changes.
- Use long sweep fittings on horizontal changes.
- For vertical to horizontal direction of changes, the Y and 45° fittings are the most appropriate one.

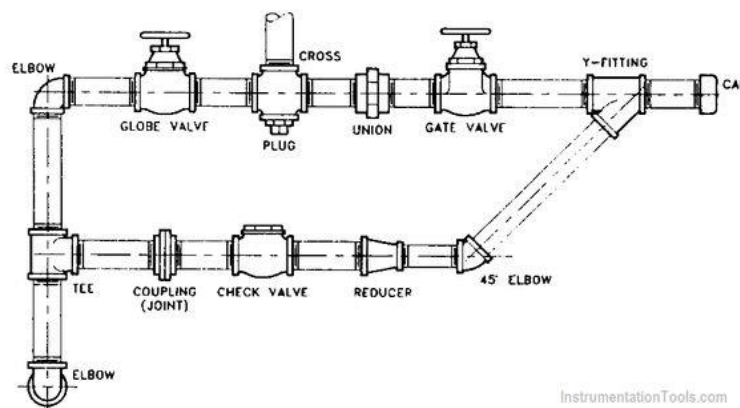

Fig-5: PVC pipe connection

Page 20 of 41	Ministry of Labor and Skills Author/Copyright	Installation of sewerage system, water supply line and sanitary appliance	Version -1
			May, 2023

Grade or slope

Slope compares the vertical change (the rise) to the horizontal change (the run) when moving from one fixed point to another along the line. It is recommended a 2% slope for the house drain should be maintained although there are instances wherein less than 2% can be provided.

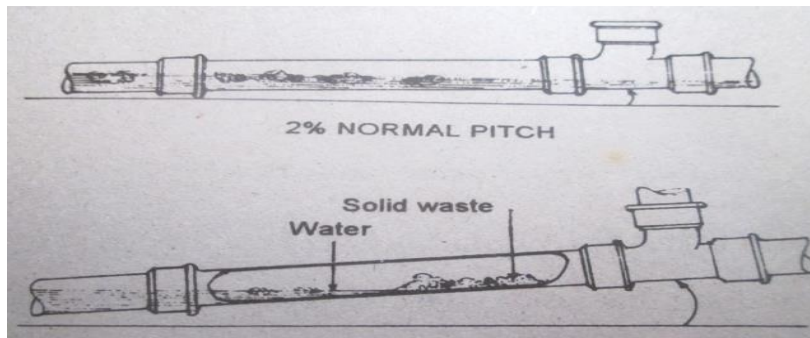

Fig-6: Slope

Page 21 of 41	Ministry of Labor and Skills Author/Copyright	Installation of sewerage system, water supply line and sanitary appliance	Version -1
			May, 2023

Self-check -2

Part-I: Choose the correct answer.

1. Which statement is correct about wastewater installation system?
 - a) Right location of clean outs.
 - b) The right slope or grade of the pipeline.
 - c) The manner of joining the pipes.
 - d) The right size of the pipe
 - e) All

2. _____ is a pipe or pipes installed to provide a flow of air to protect trap seals siphoning and back pressure.
 - a) Pipe
 - b) Trap
 - c) Fixtures
 - d) None

3. Which pipe is used to install for wastewater disposal line?
 - a) PPR pipe
 - b) GSI pipe
 - c) PVC pipe
 - d) All

Page 22 of 41	Ministry of Labor and Skills Author/Copyright	Installation of sewerage system, water supply line and sanitary appliance	Version -1
			May, 2023

Operation 2.1

Operation title: - Install wastewater disposal line.

Purpose: - To check you can install wastewater disposal line.

Requirements of Hand tools and Materials

- Hacksaw
- Tape
- Different size of PVC pipe
- Different size and types of PVC fitting

Procedure

- Read & interpret the drawing (sewerage layout)
- Measure the length of pipe properly.
- Assemble the project according to drawing.
- Give 2% slope.
- Check the project teste.

Quality Criteria: Assured performing of all the activities according to the procedures.

Precautions:

- Wearing proper clothes, eye glass, glove, safety shoes
- Make working area hazard free.
- Read and interpret manual which guide you how to use tools and equipment.
- Using hand tools for certain work for certain function

Page 23 of 41	Ministry of Labor and Skills Author/Copyright	Installation of sewerage system, water supply line and sanitary appliance	Version -1
			May, 2023

Lap Test

Instructions: - Given necessary templates, tools and materials you are required to perform the following tasks accordingly.

Task 1: Perform Assemble the project according to drawing

Task 2: Perform to given properly slope

Task 3: Perform the project test

Task 4: Perform the project quality

Page 24 of 41	Ministry of Labor and Skills Author/Copyright	Installation of sewerage system, water supply line and sanitary appliance	Version -1
			May, 2023

Unit Three: Installation of Water Supply Line component

This unit is developed to provide trainees the necessary information regarding the following content coverage and topics: -

- 3.1. Water supply system
- 3.2. Layout of water supply line
- 3.3. Connection techniques
- 3.4. Types of sanitary appliances

This unit will also assist trainees to attain the learning outcomes stated in the below.

Specifically, upon completion of this learning guide, trainee will be able to: -

- Identify water supply system.
- practice layout of water supply line
- Identify connection techniques.
- Identify types of sanitary appliances

Page 25 of 41	Ministry of Labor and Skills Author/Copyright	Installation of sewerage system, water supply line and sanitary appliance	Version -1
			May, 2023

3.1. Water Supply System

The water supply system is responsible for delivering water to toilets, showers, taps, bathtubs, sprinklers, and many appliances such as washing machines, steamers, and water heaters. Water supply to premises can be done in one of the two ways: -

Direct supply system: -All appliances of a house are directly connected to the main supply line of Municipality/city government/ supply company.

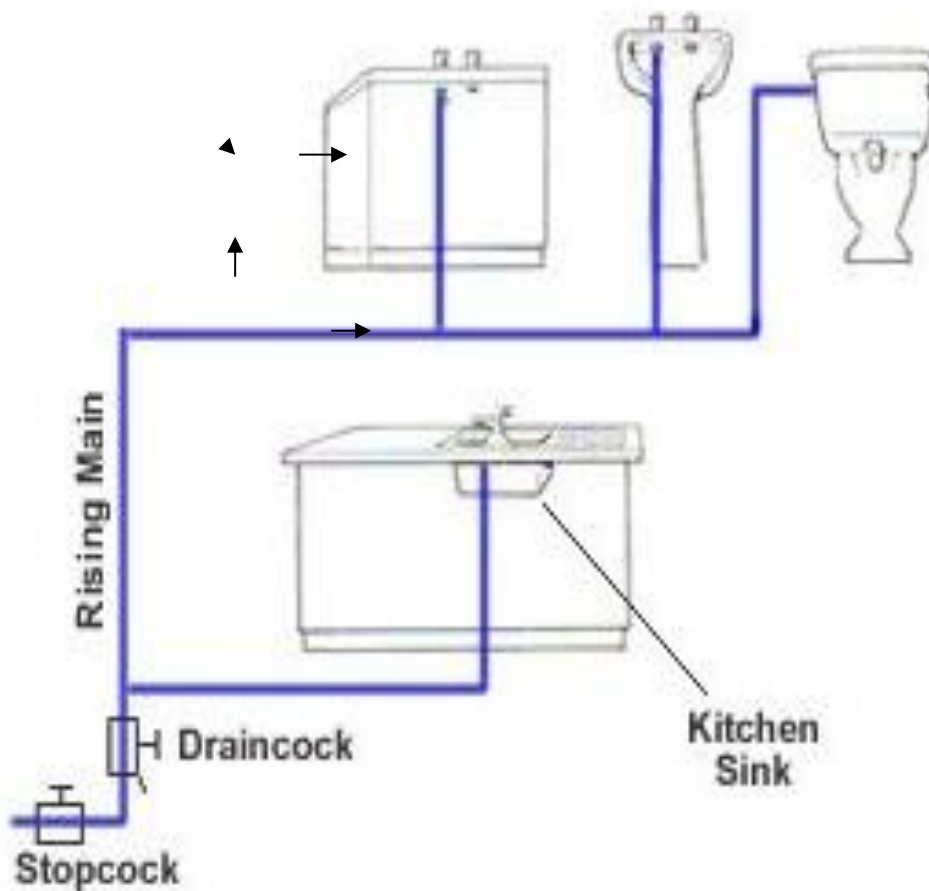

Fig-7: Direct water supply line

Page 26 of 41	Ministry of Labor and Skills Author/Copyright	Installation of sewerage system, water supply line and sanitary appliance	Version -1
			May, 2023

Indirect supply system: -Only the kitchen sink and storage tank are connected to the main supply line. All other appliances are fed with water from the storage tank on the terrace of the house. Kitchen sink can be treated like others.

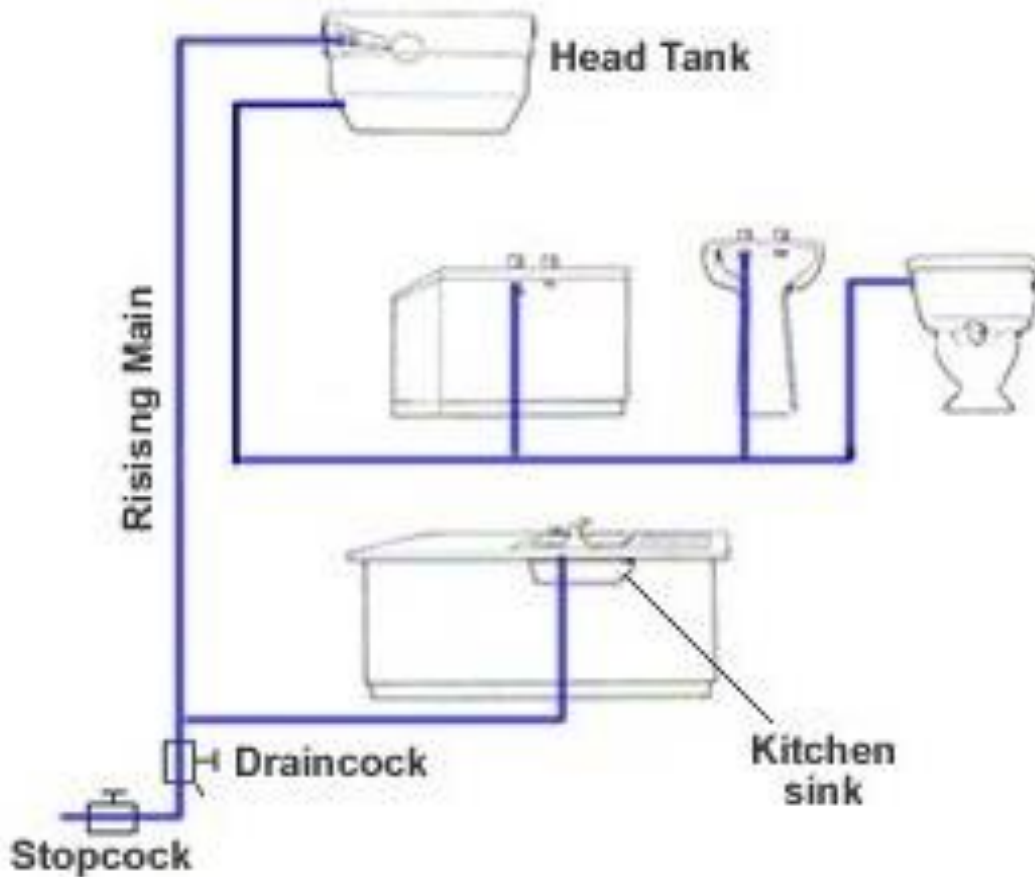

Fig-8: Indirect water supply line

Page 27 of 41	Ministry of Labor and Skills Author/Copyright	Installation of sewerage system, water supply line and sanitary appliance	Version -1
			May, 2023

3.2. Layout of Water Supply Line

A plumbing plan or a plumbing drawing is a technical overview of the system that shows the piping for fresh water going into the building or service. The layout plan view drawing which shows the plumbing system, and it is generally traced from the floor plan.

3.3. Connection Techniques

PPR installation method





PPR water pipe is the commonly used pipe in cold and hot water supply system due to its many advantages. PPR pipes and pipe fittings are connected by hot melting or electric melting. When connecting, the PPR pipes and pipe fittings are heated to critical melting at the same time. Then, the pipes are immediately inserted into the PPR pipe fittings in a straight line. The generally recommended procedure is stated below.

The following table shows the welding procedure for PPR installation and required material.

- PPR pipe
- Welder machine
- Hacksaw (cutter) and tape

Description	Pitcher
Use special scissors to cut PPR pipe, and the cut shall be smooth without burr.	

Page 28 of 41	Ministry of Labor and Skills Author/Copyright	Installation of sewerage system, water supply line and sanitary appliance	Version -1
			May, 2023

<p>Clean the welding parts of PPR pipes and pipe fittings to avoid sand, dust, and other damage to the joint quality.</p>	
<p>The heating head matched with the size of the PPR pipe to be welded is used to assemble the fuser, which is heated to 260 °C.</p>	
<p>Mark the welding depth on the PPR pipe with a marking pen</p>	
<p>At the same time, insert the PPR pipe and pipe fittings into the welding device, and heat them according to the specified time.</p>	
<p>After heating, push the pipe and pipe vertically and maintain for more than 5 seconds. Do not use too much force to prevent bending.</p>	

Galvanized steel pipe joint: - Pipe threading is the process of cutting a screw thread into a pipe. It is a vital step to join two pipe ends mechanically. GIS pipe threads are not only used to make mechanical joints but also to leak-proof gas or liquid seal. GIS steel pipe is installed within the following common treading system. The hemp packing is used to ensure that any small space between two metal threads (male and female threads) is sealed to prevent any leakage.

Galvanized steel pipe is installation system.

- a. Parallel thread
- b. Tapered thread

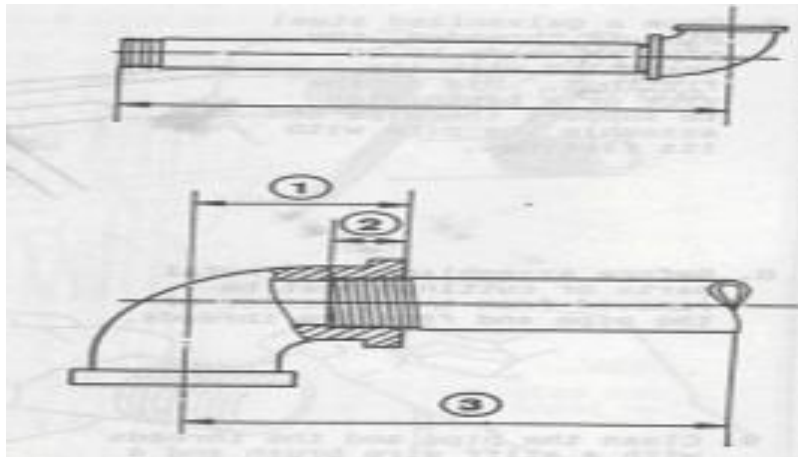
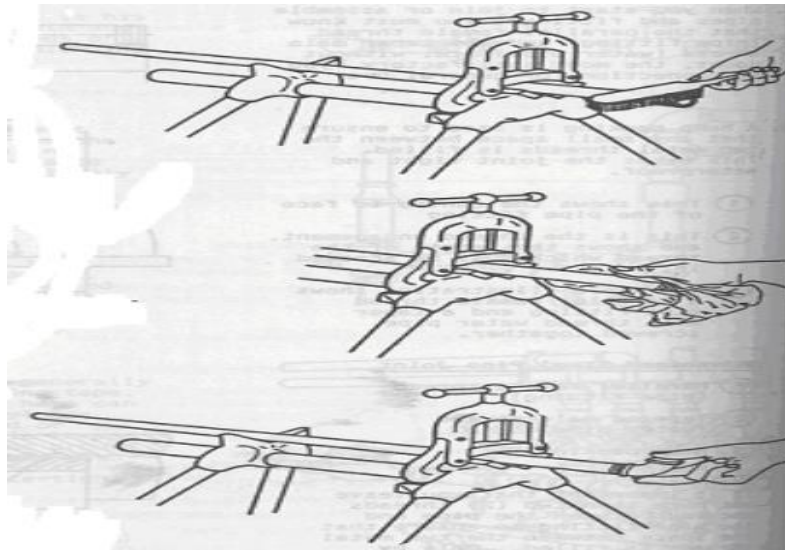

Fig-9: Assembling



Page 30 of 41	Ministry of Labor and Skills Author/Copyright	Installation of sewerage system, water supply line and sanitary appliance	Version -1
			May, 2023

Fig-10: Brushing and assembling.

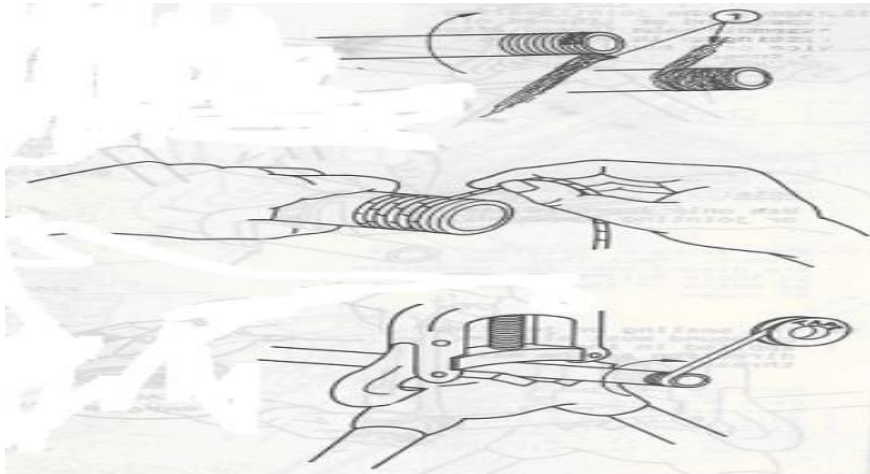

Fig-11: Hemp and packing

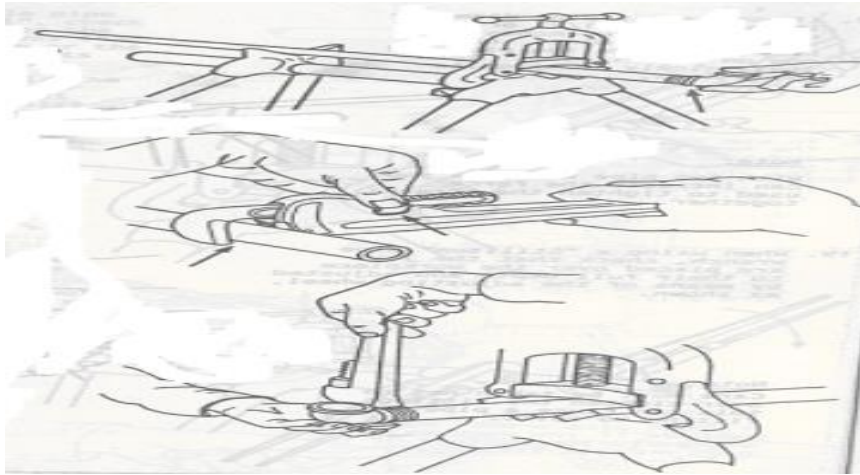
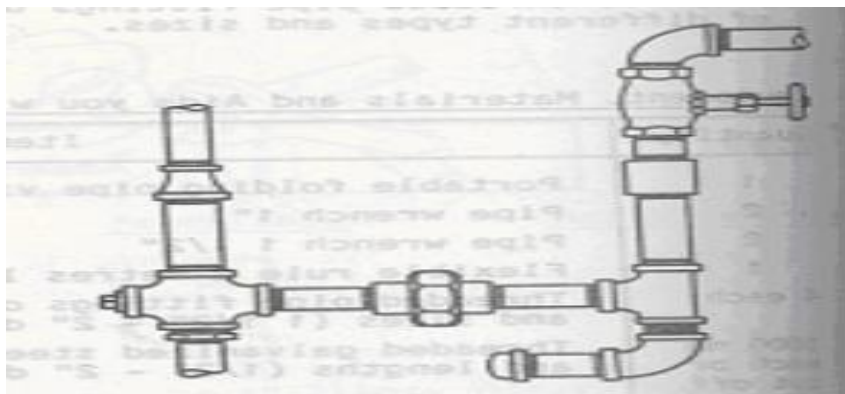

Fig-12: Pipe tighten



Page 31 of 41	Ministry of Labor and Skills Author/Copyright	Installation of sewerage system, water supply line and sanitary appliance	Version -1
			May, 2023

Fig-13: Assembled pipe

3.4. Types of sanitary appliances

Sanitary appliances are receptacles intended to receive and carried waste and discharge them into the drainage system. A plumbing fixture is a part that is connected to a plumbing system and carries water through a building.

Types of sanitary appliance are: -

- Washbasin
- Sinks
- Bathtub
- Flushing Cisterns
- Water-Closet
- Urinals

Water closet (WC): -Water closet is provided to receive human excreta directly from the user. There are subdivisions of products; WC bowls, flushing cisterns and tested combinations of bowls and cisterns known as suites.

There are two types of water closets.

- Indian type (Turkish type)
- European type (raised seat)

Page 32 of 41	Ministry of Labor and Skills Author/Copyright	Installation of sewerage system, water supply line and sanitary appliance	Version -1
			May, 2023

Technology Options	
<p>Indian type (Turkish type)</p> 	<p>1. Sato pan and Sato flex: - It is a lightweight plastic bowel that allows waste to flow towards an exit hole covered by a self-closing flap. This product can be used for new or existing toilets, fitted in concrete.</p> 
<p>European type (raisedseat)</p> 	<p>2. Aim: - it's a plastic slab with closure that can be moved with foot. Available in small and medium sizes.</p> 
<p>European type (raisedseat)</p> 	<p>3. Sato Stool: its other types of Sato product Which allows comfortable sitting position for all family members, from the young to the elderly.</p> 

Urinal (UR): Urinals are sanitary appliance comprising a bowl for receiving urine and a flushing device, e.g., a flushing cistern, delivering water used for flushing and directing both, urine, and water, into a drainage system. The common types are Wall hung, Stall and through.

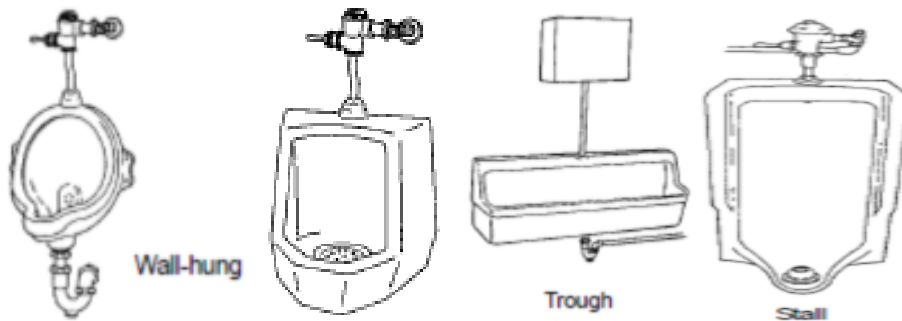

Fig-14: Different types of urinals

Hand wash basin (HWB): - A lavatory is designed for washing one's hands and face. Lavatories come in a variety of shapes, sizes, and colours. They can be made of vitreous China, enamelled cast iron, stainless steel, concrete and plastic.



Fig-12: Different types of HWB

Page 34 of 41	Ministry of Labor and Skills Author/Copyright	Installation of sewerage system, water supply line and sanitary appliance	Version -1
			May, 2023

Self-check -3

Part I: Choose the Correct Answer.

1. Which one is easier to install water supply line?
 - a) PPR pipe
 - b) GSI pipe
 - c) Cast iron pipe.
 - d) All

2. How many water supply installation lines are there?
 - a) Two
 - b) One
 - c) Four
 - d) Tree

4. Which installation system is best installation?
 - a) Direct
 - b) Indirect

Part II: Match the following questions.

Column A

1. Direct water supply system
2. Indirect water supply line
3. PPR installation system
4. GSI pipe installation system

Column B

- a) Install within a storage tanker.
- b) Without a storage tanker
- c) Best installation method.
- d) Old installation method

Page 35 of 41	Ministry of Labor and Skills Author/Copyright	Installation of sewerage system, water supply line and sanitary appliance	Version -1
			May, 2023

Operation 3

Part I

Operation Title: - Install indirect water supply within a PPR pipe.

Purpose: - To check trainees if they can install water supply line with in PPR pipe.

Required hand tools and Materials.

- PPR pipe
- Different types of PPR fitting
- PPR welder machine

Procedure / step

1. Read & interpret the drawing (supply layout)
2. Assemble the project according to drawing.
3. Check the project is done according to drawing or not.
4. Check the project test.
5. Clean up.

Quality Criteria: Assured performing of all the activities according to the procedures.

Precautions:

- Wearing proper clothes and safety shoes
- Make working area hazard free.
- Read and interpret manual which guide you how to use tools and equipment.

Page 36 of 41	Ministry of Labor and Skills Author/Copyright	Installation of sewerage system, water supply line and sanitary appliance	Version -1
			May, 2023

Operation 4

Operation Title: - Install hand wash basin with fully accessory.

Requirements of hand Tools and Materials

- Portable drill
- Screwdriver
- Pipe wrench
- Sprit level
- Plastic tanker

Procedure

1. Read & interpret the drawing basin place.
2. Drill the bowl hole on the wall.
3. Connect the water line with faucet.
4. Check the level of the basin.
5. Check the connection of the trap.
6. Check the flush of faucet properly on basin.

Quality Criteria: Assured performing of all the activities according to the procedures.

Precautions:

- Wearing proper clothes and safety shoes
- Make working area hazard free.
- Read and interpret manual which guide you how to use tools and equipment.

Lap Test

Instructions: - Given necessary templates, tools, and materials you are required to perform the following tasks accordingly.

Task 1: Perform fixed the project according to drawing

Task 2: Perform project leakage or not

Task 3: Perform the level of basin

Task4: perform connection of the trap.

Task 5: Perform flushing the faucet properly on the basin

Quality Criteria: Assured performing of all the activities according to the procedures.

Precautions:

- Wearing proper clothes and safety shoes
- Make working area hazard free.
- Read and interpret manual which guide you how to use tools and equipment.

References books

1. Steve Muscroft (2007). Plumbing. Burlington: Elsevier Ltd. <http://elsevier.com/locate>
2. Gil L. Taylor (2005). Plumbing and Piping Systems. United States of America: The McGraw-Hill Companies, Inc.
3. Government of Western Australia department of training and workforce department (2014). Carry out basic measurements and calculations for residential buildings.
4. Brian Silowash, PE, CEM, LEED AP (2010). Piping System Manual. New York Chicago San Francisco: The McGraw-Hill Companies
5. Practical plumbing book volume I, II, III
6. Water supply and sanitary engineering book
7. EBCS-9 20123

Participants of This Module (Training Material) Preparation

No	Name	Qualification (Level)	Field of Study	Organization/ Institution	Mobile number	E-mail
1	Andualem Abebayehu	MSc	Hydraulics and Water Resource Engineering	Debark PTC	0982095105	andualemabebayhu@gmail.com
2	Mesfin Wondimu	BSc	Construction Technology and Management	Aleta Wondo PTC	0916981613	mesfinwondimu@gmail.com
3	Girema Moges	BSc	Civil Engineering	Wolayita PTC	0911530068	girmamoges@gmail.com
4	Dagim Fekadu	MSc	Construction Technology and Management	Ambo PTC	0910140914	dag.astu.2005@gmail.com
5	Solomon Tadesse	BSc	Construction Technology and Management	GWPTC	0921414347	soletadss@gmail.com
6	Esmael Mohammed	BSc	Water Work construction technology	Kombolcha PTC	0915543225	Bad9565@gmail.com
7	Desalegn Alemu	BSc	Construction Technology and Management	Woliso PTC	0926771683	desalgnalen@gmail.com
8	Tesfaye Assegidew	MSc	Construction Technology and Management	Butajira PTC	0913442444	tesfayeasegidew@gmail.com
9	Mulualem Misganaw	BSc	PLSC	MOLS	0910463950	mulu9192@gmail.com
10	Bacha Kitesa	MPH, MA	Environmental Health since, public health, Project Management	PSI	0910757797	bachakitesa@gmail.com
11	Mesfin Habtemariam	MA, BSc	Civil Engineering	PSI	0911124992	mesfinhabtemariam@gmail.com
12	Fisum G/Egizeebiher	MPH	Environmental Health Science	PSI	0913222354	fegziabher@psiet.org
13	Ziyade Ahmed	MPH	Environmental Health Science	MOH	0916586603	
14	Wondayehu Wube	BSc, MPH	Environmental Health Science	MOH	0972651005	wondayehuwube@gmail.com

